

**Baker Instrument Company, an SKF Group Company**

4812 McMurry Ave. Suite 100  
Fort Collins, CO 80525  
(970) 282-1200  
(970) 282-1010 (FAX)  
800-752-8272 (USA Only)

**Note:** This equipment has been tested and found to comply with the limits for a Class A digital device, pursuant to Part 15 of the FCC rules. These limits are designed to provide reasonable protection against harmful interference with the equipment is operated in its installation. This equipment generates uses and can radiate radio frequency energy and, if not installed and used in accordance with the product manual, may cause harmful interference to radio communications. If this equipment does cause harmful interference, the user will be required to correct the interference.

Due to the phenomena being observed and the material properties being measured, this equipment does radiate radio frequency energy while in the active test mode. Care should be taken to insure this radio frequency energy causes no harm to individuals or other nearby equipment.

Information furnished in this manual by Baker Instrument Company, an SKF Group Company,, is believed to be accurate and reliable. However, Baker Instrument Company, an SKF Group Company, assumes no responsibility for the use of such information or for any infringements of patents or other rights of third parties that may result from its use. No license is granted by implication or otherwise under any patent rights of Baker Instrument Company, an SKF Group Company.

**Warning:**

Baker Instrument Company, an SKF Group Company, assumes no liability for damages consequent to the use of this product. No part of this document may be reproduced in part or in full by any means such as photocopying, photographs, electronic recording, videotaping, facsimile, etc., without written permission from Baker Instrument Company, an SKF Group Company, Fort Collins, Colorado.

**Intended use of instrument**

The EXP4000 is intended for detection motor efficiency and physical performance deterioration, and other electrical problems within electric machines by trained professionals. It is intended to perform only the specified tests that this manual explains in detail. Please refer to chapters in this manual concerning specific operation of the instrument

**Note on Software**

While the UNIT is a Microsoft Windows® based instrument, it is specially configured and optimized to perform the functions for which it was designed. The loading or operation of unauthorized software may cause the instrument to malfunction or cease functioning and may void the manufacturer's warranty.

**Software License Agreement**

UNIT - test equipment and desktop versions.

**Carefully read the following terms and conditions before opening the software envelope or operating the UNIT.** Either opening the envelope or using the software constitutes your acceptance of these terms and conditions on behalf of any party using the instrument (the "User"). If you or the User do not agree with these terms, promptly return the instrument with the envelope unopened for a full refund.

**1. Definitions**

(a) **Computer Software:** A Software program provided with the Instrument on CD or other physical medium for installation and use on the User's desktop computer(s) or servers, and all updates, upgrades, enhancements and modifications provided directly or indirectly to the User from time to time.

(b) **Documentation:** This User's Manual and other manuals and documentation relating to the Instrument and provided directly or indirectly to the User in the original Instrument carton or from time to time thereafter.

(c) **Instrument:** The unit of test equipment with which this User's Manual was provided to the User.

(d) **Instrument Software:** The software program pre-loaded on the Instrument, and all updates, upgrades, enhancements and modifications provided directly or indirectly to the User from time to time.

(e) **Software:** The Instrument Software and/or Computer Software, as the context requires.

(f) **Intellectual Property Rights:** All rights arising or protectable under the copyright, trademark, patent, or trade secrets laws of the United States or any other nation, including all rights associated with the protection of computer programs and/or source code.

(g) **Person:** An individual, a partnership, a company, a corporation, an association, a joint stock company, a trust, a joint venture, an unincorporated organization, or a

governmental entity (or any department, agency, or political subdivision thereof).

**2. License; Related Terms.**

(a) **Grant of License.** Baker/SKF grants the User, pursuant to the terms and conditions of this Software License, a non-exclusive, non-transferable, and revocable license to (i) use the Instrument Software only on the Instrument, (ii) the Computer Software(s) on the numbers and types of desktop and/or other computers specified elsewhere in this User's Manual, (iii) reproduce the Software only as necessary to use it and create no more than two copies of the Software in machine readable form for back-up purpose only; provided in each case that the copy shall include Baker/SKF's copyright and any other proprietary notices, and (iv) utilize the Documentation only in conjunction with the use of the Software.

(b) **Restrictions on Use.** The User shall not (i) permit any parent, subsidiaries, affiliated entities or third parties to use the Software; (ii) grant third parties use of the Software on a service bureau, application service provider or other similar basis; (iii) rent, resell, lease, timeshare or lend the Software to any Person; (iv) sublicense, assign, or transfer the Software or this license for the Software to any third party, (v) reproduce the Software other than as expressly authorized herein, or distribute, or publicly display the Software; (vi) make the Software accessible to any Person by any means, including posting on a web site or through other distribution mechanisms over the Internet; (vii) reverse assemble, disassemble, reverse engineer, reverse compile, decompile, or otherwise translate the Software or prepare Derivative Works based on the Software; (viii) place, reproduce, or make available the Software on the User's computer network if the User is only authorized by this Software License to operate the Software on a single workstation; (ix) exceed at any given point in time the total number of network clients authorized by the applicable purchase order or ordering document to use or access the Software; or (x) edit or modify the Software except as expressly authorized by Baker/SKF, including altering, deleting, or obscuring any proprietary rights notices embedded in or affixed to the Software.

(c) **Protection of Software.** The User will take action by instruction, written agreement, or otherwise as appropriate with any person

permitted access to the Software to enable the User to comply with its obligations hereunder.

(d) Material Terms and Conditions. The User acknowledges that each of the terms and conditions of this Section 2 is material and that failure of the User to comply with these terms and conditions shall constitute sufficient cause for Baker/SKF to terminate this Software License and the license granted hereunder immediately and without an opportunity to cure. This subsection 2(d) shall not be construed to preclude, or in any way effect, a finding of materiality with respect to any other provision of this Software License.

**3. Ownership.** Baker/SKF, as between Baker/SKF and the User, owns all Intellectual Property Rights related to the Software, including custom modifications to the Software, whether made by Baker/SKF or any third party. The User agrees that this Software License effects a license, not a sale, of the Software and that the first sale doctrine, as codified in 17 U.S.C. § 109, does not apply to the transaction effected by this Software License.

**4. Confidential Information.** The Software contains proprietary information, including trade secrets, know-how and confidential information (hereinafter referred to collectively as the “**Confidential Information**”), that is the exclusive property of Baker/SKF. During the period this Software License is in effect and at all times after its termination, the User and its employees and agents shall maintain the confidentiality of the Confidential Information and shall not sell, license, publish, display, distribute, disclose or otherwise make available the Confidential Information to any Person nor use the Confidential Information except as authorized by this Software License. The User shall not disclose the Confidential Information concerning the Software, including any flow charts, logic diagrams, user manuals and screens, to persons not an employee of the User without the prior written consent of Baker/SKF.

**5. Limited Warranties; Disclaimer**

(a) Baker/SKF’s sole and exclusive warranties with respect to the Instrument and Software are set forth in this User’s Manual.

(b) EXCEPT AS SET FORTH IN THIS USER’S MANUAL AND TO THE EXTENT PERMITTED BY APPLICABLE LAW, ALL EXPRESS AND/OR IMPLIED WARRANTIES OR CONDITIONS, INCLUDING BUT NOT LIMITED TO IMPLIED WARRANTIES OR CONDITIONS OF MERCHANTABILITY, MERCHANTABILITY OF A

COMPUTER PROGRAM, INFORMATIONAL CONTENT, SYSTEM INTEGRATION, FITNESS FOR A PARTICULAR PURPOSE, AND NON-INFRINGEMENT, ARE HEREBY DISCLAIMED AND EXCLUDED BY BAKER/SKF.

**6. Limitations on Liability**

(a) Limitations and Exclusions. IN NO EVENT WILL BAKER/SKF BE LIABLE TO LICENSEE FOR ANY DIRECT, INDIRECT, INCIDENTAL, CONSEQUENTIAL, PUNITIVE OR OTHER SPECIAL DAMAGES, LOST PROFITS, OR LOSS OF INFORMATION SUFFERED BY LICENSEE ARISING OUT OF OR RELATED TO THE INSTRUMENT OR THE USE OF THE INSTRUMENT, FOR ALL CAUSES OF ACTION OF ANY KIND (INCLUDING TORT, CONTRACT, NEGLIGENCE, STRICT LIABILITY, BREACH OF WARRANTY OR CONDITION, AND STATUTORY) EVEN IF BAKER/SKF HAS BEEN ADVISED OF THE POSSIBILITY OF SUCH DAMAGES. THE PRECEDING EXCLUSION AND DISCLAIMER OF DAMAGES SHALL APPLY TO ALL CLAIMS MADE BY LICENSEE RELATED TO OR ARISING OUT OF LICENSEE’S USE OF THE SOFTWARE, INCLUDING, BUT NOT LIMITED TO, CLAIMS ALLEGING THAT THE SOFTWARE, OR ANY COMPONENT THEREOF, FAILED OF ITS ESSENTIAL PURPOSE OR FAILED IN SOME OTHER RESPECT.

(b) Acknowledgment. The User agrees that the limitations of liability and disclaimers of warranty set forth in this Software License will apply regardless of whether Baker/SKF has tendered delivery of the Software or the User has accepted the Software. The User acknowledges that Baker/SKF has set its prices and granted the licenses contemplated herein in reliance on the disclaimers of warranty and the limitations and exclusions of liability set forth in this Software License, and that the same form an essential basis of the bargain between the Parties.

**7. Term and Termination**

(a) Term. The licenses granted herein shall commence on the User’s acceptance of the terms of this Software License, and shall continue in existence until it is terminated in accordance with Section 7(b) below.

(b) Termination. Baker/SKF may terminate this Software License and the license conveyed hereunder in the event that the User breaches any provision, term, condition, or limitation set forth in this Software License, including but not limited to the license restrictions set forth in Section 2(b) of this Software License.

(c) Effect of Termination. Within ten (10) days after termination of this Software License and

the licenses granted hereunder, the User shall return to Baker/SKF, at the User's expense, the Computer Software and all copies thereof, and deliver to Baker/SKF a certification, in a writing signed by an officer of the User, that all copies of the Computer Software have been returned to Baker/SKF and that the User has complied with the requirements of this Section 7(c).

**8. Assignment.** The User may assign this Software License in connection with the sale or other transfer of the Instrument, provided, that the transferee agrees in writing to be bound by the terms of this Software License. Except as authorized by the preceding sentence, the User shall not assign or otherwise transfer the Software or this Software License to anyone, including any parent, subsidiaries, affiliated entities or third Parties, or as part of the sale of any portion of its business, or pursuant to any merger, consolidation or reorganization, without Baker/SKF's prior written consent. Any assignment or transfer effected in violation of this Section 8 shall be void ab initio and of no force or effect.

**9. General.** The validity and interpretation of this Software License shall be governed by Colorado Law except as to copyright and other proprietary matters, which may be preempted by United States laws and international treaties. In the event of any violation of this Software License, Baker/SKF reserves the right to pursue any state law remedies (including contractual remedies) or remedies under federal laws or both. The User consents to exclusive jurisdiction in either state or federal courts in Colorado or both as appropriate and agrees that the prevailing party shall be entitled to its attorney fees and costs. No decision, act or inaction of Baker/SKF, shall be construed to be a waiver of any right or remedy, and pursuit of any state or federal causes shall not be deemed an election or remedies. In the event of any provision of this Software License shall be deemed unenforceable, or void, or invalid, such provision shall be modified so as to make it valid and enforceable and as so modified the entire agreement shall remain in full force and effect. This Software License sets forth the entire understanding and agreement between the parties and no written or oral representative of any kind whatsoever shall in any way modify or expand the terms of this User's Manual.

In the event of any conflict or inconsistency between the terms of this Software License and any Documentation, this agreement shall preempt such documentation to the extent inconsistent.

**WARNING:** All material associated with this Software License is copyrighted material. Federal law provides severe civil and criminal penalties for the unauthorized reproduction, distribution, or use of copyrighted materials (Title 17, United States Code). The Federal Bureau of Investigation investigates allegation of criminal infringement for enforcement. Should you have any questions concerning this User's Manual, you may contact Baker/SKF, at 4812 McMurry Avenue, Suite 100, Fort Collins, Colorado 80525. Telephone 970-282-1200; Fax 970-282-1010, [www.bakerinst.com](http://www.bakerinst.com).

**Important notice concerning warranty and repairs**

The warranty is void if (i) the UNIT is shipped without shock absorbing packing material, (ii) the UNIT is damaged by improper use, (iii) any party other than Baker/SKF modifies the Software or loads or operates unauthorized software programs on the UNIT, or (iv) the User has breached the Software License set forth above. The User assumes all responsibility and expense for removal, reinstallation, freight, or on-site service charges in connection with the foregoing remedies.

Baker/SKF's liability to purchaser relating to the product whether in contract or in part arising out of warranties, representations, instructions, installations, or defects from any cause, shall be limited exclusively to correcting the product and under the conditions as aforesaid.

If the UNIT fails, whether it is under warranty or not, call the Baker/SKF service department before returning the unit for repair. If the unit needs in-house repair, our service staff might direct you to ship the unit to the authorized service center closest to you. This might save both time and money. When calling the Baker service department or one of the service centers, please have the model and serial numbers available. These numbers are located on the rear of the instrument. If the unit is out of warranty, a purchase order will be required if the unit is returned for repair.

### **Virus Alert**

The UNIT contains computer software that is vulnerable to damage from computer viruses. Before shipping, Baker/SKF scanned all data to ensure the UNIT is virus-free. Before inserting any disks into the disk drive or connecting the UNIT to a computer network, scan all disks for viruses.

### **Trademarks**

All other trademarks, service marks or registered trademarks appearing in this manual are the trademarks, service marks or registered trademarks of their respective owners.



## Table of Contents

---

Intended use of instrument .....	1
Note on Software .....	2
Software License Agreement .....	2
1. Definitions .....	2
Virus Alert .....	5
Trademarks .....	5
<b>Preface .....</b>	<b>13</b>
Important safety information .....	13
General Safety Precautions .....	13
Safety term definition .....	13
Symbols/Labels on equipment .....	13
Other Important Safety Warnings .....	14
Operational safety warnings .....	14
Technical assistance / Authorized service centers .....	15
Accessory interconnection and use .....	15
Intermittent operation limits .....	15
Cleaning & decontamination .....	15
Installation requirements .....	15
Pollution degree II .....	15
Power requirements .....	15
Environment conditions/storage .....	15
Unpacking the unit .....	15
Shipment .....	16
<b>1 .....</b>	<b>17</b>
<b>EXP4000 tests .....</b>	<b>17</b>
Test domains/testing theory .....	17
Testing Capabilities .....	17
Power quality domain .....	17
Voltage Level Test .....	17
Voltage Unbalance Test .....	18
Harmonic Distortion .....	18
Total Distortion .....	18
Power .....	19
Harmonics .....	20
Machine performance domain .....	20
Effective service factor .....	20
Load .....	21
Operating Condition .....	21
Efficiency .....	22
Payback Period .....	23
Current Domain .....	23
Overcurrent .....	23
Current Unbalances .....	24
Spectrum Domain .....	24
Rotor bar/Operating condition .....	24
V/I Spectrum .....	25
Harmonics .....	25
Connection Domain .....	26
Waveforms .....	26
ABC/SYM Comp .....	26
Phasors .....	26
Declaration of conformity .....	28
<b>2 .....</b>	<b>29</b>
<b>Getting started .....</b>	<b>29</b>
Configuring software for motor data .....	29
Database Management .....	29
8/17/2010   71-005 V3 EN	7
EXP4000	

## Table of Contents

Consequences of not organizing data into databases .....	29
Plant maintenance:.....	29
Database features .....	29
Navigating through the software interface .....	29
EXP4000 software specific features.....	29
Grey shaded fields.....	29
Text fields.....	29
Arrows and Windows icons .....	29
Numeric Fields.....	30
Starting the software.....	30
Numerical fields.....	31
Domain panel.....	31
Results panels.....	31
Test log panel .....	32
Software navigation - finding machines.....	32
Icons Displayed within Machine Tree.....	33
Upgrading databases from previous software versions .....	33
Printer configuration.....	34
Keyboard shortcuts: .....	34
Software hints .....	34
<b>3 .....</b>	<b>35</b>
<b>Basic software overview .....</b>	<b>35</b>
Software overview.....	35
File menu items.....	35
Database.....	35
Print summary report.....	36
Reports.....	36
Exit.....	37
Machine menu items .....	37
Machine tree .....	38
Create machine.....	39
Name plate.....	39
Sensor ratio .....	39
Machine information.....	40
Motor design/Energy information.....	40
Edit machine .....	41
Delete a machine .....	41
Acquire EP serial number .....	41
Reset EP serial number.....	41
Thresholds menu.....	41
Assign test model.....	42
Create elec. test model.....	42
Edit test model.....	43
Delete test model .....	43
Tools menu items.....	43
Scope .....	43
View connections.....	44
Transient analysis .....	45
Loop acquisition.....	46
Stator resistance estimator .....	46
Motor Master +.....	47
IEC efficiencies .....	47
Options menu items.....	48
Test notes.....	48
Override speed.....	49
Electrical acquisition options.....	49
Spectrum acquisition options.....	49



Table of Contents

Spectrum acquisition options .....	50
EP acquisition options.....	50
Daq card settings.....	50
Display options.....	51
<b>4 .....</b>	<b>53</b>
<b>Torque software overview .....</b>	<b>53</b>
T3000 torque analysis software .....	53
Spectrum domain – demodulated spectrum option .....	53
Demodulated spectrum.....	53
Torque domain .....	54
Torque ripple .....	55
Torque spectrum.....	55
Right Click menu .....	56
<b>5 .....</b>	<b>59</b>
<b>VFD software.....</b>	<b>59</b>
VFD3000 (VFD analysis software) .....	59
Operation details .....	59
VFD mode.....	59
Phasors .....	60
Waveforms .....	60
VFD details domain.....	61
<b>6 .....</b>	<b>63</b>
<b>Continuous monitoring software .....</b>	<b>63</b>
Continuous monitoring (streaming).....	63
File menu.....	63
Machine menu .....	63
Machine menu .....	64
Tools menu.....	64
View Menu.....	64
Options .....	66
Graph Plot Mode .....	66
Event triggers .....	66
General operation icons.....	67
Modifying continuous monitoring tool .....	67
Adding a new gauge or graph.....	67
Editing gauges and graphs .....	68
Channel description.....	70
<b>7 .....</b>	<b>71</b>
<b>Vibration software overview .....</b>	<b>71</b>
Vibration Models .....	71
Vibration Application .....	71
Vibration App .....	71
Running a vibration scan.....	72
Running a looped acquisition scan .....	72
Running a timed looped acquisition .....	72
Viewing results.....	73
View results – Time waveform .....	73
View Results - Spectrum.....	75
View Results - Trending .....	77
Graph Tools .....	79
Graph Tools .....	80
Exporting data.....	80
<b>8 .....</b>	<b>81</b>
<b>DC software overview .....</b>	<b>81</b>
DC machine Dynamic analysis software .....	81
DC summary of tests & features .....	81
Types of problems identified with DC3000 .....	81

## Table of Contents

DC connections for the EXP4000 portable sensors:	81
DC sensor voltage ratings	81
Connection cases	82
Voltage sensor connections:	83
DC3000 software navigation and overview	83
Creating a new database	84
Opening a database	84
Close database	84
Creating a new folder	84
Renaming a new folder	85
Create a new test item	85
Adding an DC machine	85
Right click menu items	86
Database or Folder View	86
Online testing menu	87
Create DC test model	87
Edit test model	87
Delete Test Model	88
Looped Acquisition	88
Tools menu	89
Options	89
General options:	89
Database	90
Archive	90
Software testing screen	90
Software testing screen	91
CT selection	91
Nameplate Information	91
Center Screen	91
Bottom Main Screen	92
Run Electrical	92
View Connections	92
Exit	93
Test Domains	93
Results:	93
Drive	93
Armature voltage level (Va)	93
DC machine Va troubleshooting	94
Field voltage level (Vf)	94
DC machine VF troubleshooting	95
Result: $ Vf  >  Vf\_base\_speed $ :	95
Armature Voltage Form Factor	97
Armature Current Ripple	98
Machine	99
Armature current level	99
High Field Resistance	100
Low field resistance	100
Field current level	101
Load	102
Torque ripple	103
Load level	103
Waveforms	104
Spectrum	104
Field Spectrum	104
Armature spectrum	105
Torque spectrum	106
Harmonics	106

Reports.....	107
<b>9 .....</b>	<b>111</b>
<b>Physical connection of the the EXP4000/Connection setup wizard .....</b>	<b>111</b>
Connecting the EXP4000 .....	111
Important safety information .....	111
General Safety Precautions .....	111
Safety term definition .....	111
Symbols/Labels on equipment .....	111
Other Important Safety Warnings .....	112
Operational safety warnings .....	112
Physical Setup of EXP4000 with portable sensors.....	113
To connect the EXP4000 to the MCC .....	113
To connect the EXP4000 to the motor terminals:.....	114
Physical Setup of the EXP4000 with EP's.....	114
Disconnecting the EXP4000 .....	114
Connection setup wizard .....	114
Autophasing messages .....	114
Using the setup wizard.....	115
Troubleshooting CT connections.....	116
Error .....	116
Reason for error .....	116
Possible resolution .....	116
The Suggest button .....	117
Two CT solution:.....	117
Manually adjusting phasors: .....	118
<b>10 .....</b>	<b>121</b>
<b>Example test and report generation.....</b>	<b>121</b>
Important safety information .....	121
General Safety Precautions .....	121
Safety term definition.....	121
Symbols/Labels on equipment .....	121
Other Important Safety Warnings .....	122
Operational safety warnings .....	122
Motor monitoring.....	123
Looking at gathered data .....	123
Adjusting parameters .....	123
Other adjustments .....	124
Looped acquisition/Timed acquisition .....	125
Creating reports from the report generator .....	125
Viewing, annotating, and printing reports.....	127
Automatic generation of reports.....	127
Printing reports directly from results panel (single report).....	127
Printing reports from the summary page .....	128
<b>Appendix A .....</b>	<b>129</b>
<b>Default settings.....</b>	<b>129</b>
Default settings.....	129
<b>Appendix B .....</b>	<b>131</b>
<b>Troubleshooting .....</b>	<b>131</b>
Connection troubleshooting .....	131
General.....	131
Non VFD mode: .....	131
Frequently Asked Questions: .....	132
<b>Appendix C: .....</b>	<b>135</b>
<b>Blue results.....</b>	<b>135</b>
Conditions under which test show blue results:.....	135
<b>Appendix D .....</b>	<b>137</b>
<b>EP1000 installation .....</b>	<b>137</b>

## Table of Contents

---

What to do first:.....	137
Tools Needed:.....	137
Materials Needed: .....	137
Safety Precautions for EP installation.....	138
Installation safety warnings .....	138
Hardware Installation .....	138
Choosing a suitable location for the EP: .....	139
Choosing a suitable location for the panel plug:.....	139
Current Transformer (CT) Connections: .....	139
Voltage Connections:.....	140
Electrical Connections:.....	140
Verification of Installation:.....	140
Troubleshooting:.....	140
EP1000 Ratings:.....	140
<b>Appendix E .....</b>	<b>145</b>
<b>References .....</b>	<b>145</b>
List of References: .....	145
Glossary of Terms .....	145
<b>Appendix F .....</b>	<b>149</b>
<b>Technical specifications .....</b>	<b>149</b>
<b>Index .....</b>	<b>151</b>

# Preface

## Important safety information

---

### General Safety Precautions

**Note:** The general safety information presented here is for both operating and service personnel. Specific “warnings” and “cautions” will be found throughout this manual where they apply.

**Note:** If the equipment is used in any manner not specified by Baker Instrument Company, an SKF Group Company, the safety protection provided by the equipment may be impaired.

### Safety term definition



**DANGER:** Indicates a hazardous situation, which, if not avoided, will result in death or serious injury.

**WARNING:** Indicates a hazardous situation, which, if not avoided, could result in death or serious injury.

**CAUTION:** Indicates a hazardous situation, which, if not avoided, could result in minor or moderate injury.

**NOTICE:** This signal word addresses practices that could result in property damage but not personal injury.

### Symbols/Labels on equipment

	Caution: Indicates a hazardous situation which, if not avoided, could result in personnel injury and/or equipment damage.
	Voltage level warning. Located on labeling for test leads on right side of instrument

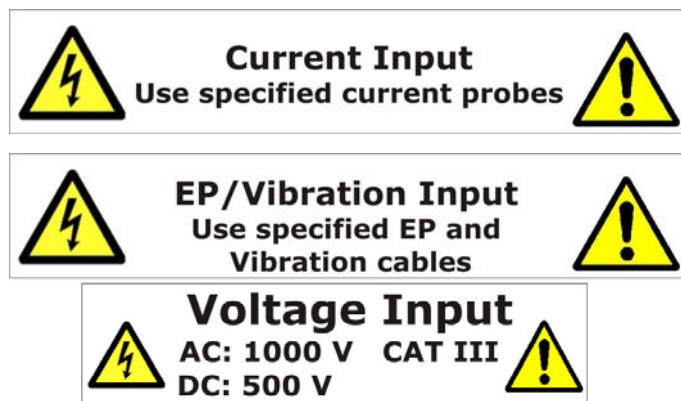

Fig Pre-1: Safety Labels from EXP4000

## Other Important Safety Warnings

- 1) **Warning:** When the instrument exterior case is open, the instrument is not water resistant. Do not allow the opened instrument to be exposed to water. Water in contact with the interior of the instrument compromises protection features and could result in serious injury or death.
- 2) **Warning:** Because of the voltages present, testing should be conducted only by trained personnel, and adequate safety precautions must be followed to minimize the risk of serious injury, death, or property damage.
- 3) **Warning:** Because of the dangerous currents, voltages, and forces encountered when operating, testing or repairing rotating equipment, safety precautions must be taken for all tests. Follow all safety precautions in this manual and required by your employer. Due to the wide diversity of machine applications, it is impossible to list all general safety precautions. However, this manual includes special safety precautions applicable to the use of the EXP4000.
- 4) **NOTICE** The maximum rating of the EXP4000 is 1,000 V (500 V for DC operation). 1,000 V (500 V DC operation) is the maximum allowable voltage between any two of the four voltages and the ground clip. Under no circumstances connect the voltage sensing circuit to higher voltage levels. Doing so will cause severe damage to instrument.

## Operational safety warnings

Baker Instrument Company, an SKF Group Company, recommends that the operator comply with the following safety precautions:

- 1) Comply with all your facility's safety practices at all times.
- 2) Ensure physical setup does not interfere with your facility's current or intended operation.

Additionally, these safety precautions must be followed, otherwise dangerous shock hazards may exist:

- 1) Use whatever safety equipment required by your organization including eye protection, high voltage gloves, arc-flash rated masks, hoods and any required PPC. Prior to opening any MCC (Motor Control Cabinet), ensure that appropriate arc-flash protection clothing is worn.
- 2) Ensure that appropriate lockout / tag-out procedures are properly understood and implemented by all personnel.
- 3) **Every connection at MCC must be done while rotating system is powered down.**
- 4) Depending on the kind of test to be run, ensure no physical proximity to the shaft of the motor or any other moving part of the machinery.
- 5) Do not position motor phase connections near ground or near each other.
- 6) Do not touch the connections, PT's, CT's or any component under test while a test is being made.
- 7) This product is grounded through the grounding conductor of the power cord if running on AC power.
- 8) Voltage ground clip must be connected to ground when the unit is running on battery power.
- 9) Remove the power cord from both the wall outlet and unit if it is running on battery power and not plugged into a wall outlet.
- 10) Do not coil power cord or test leads near motor leads.
- 11) During repairs, do not substitute any parts. Use only factory-supplied parts.
- 12) This instrument is **NOT** approved for use in an explosive environment.

## Technical assistance / Authorized service centers

For all service centers, please visit our website at [www.bakerinst.com](http://www.bakerinst.com) and click on Representatives. Service centers will be marked with asterisks.

## Accessory interconnection and use

Several accessories are available for the EXP4000. These accessories are listed in following chapters in the manual. They are to be used only as instructed.

## Intermittent operation limits

At this time there are no intermittent operation limits for the EXP4000 unit.

## Cleaning & decontamination

The EXP4000 should be kept clean and in a dry environment. To clean the unit, wipe with a clean, water-dampened cloth. Do not submerge in water or other cleaners or solvents. To clean the screen, take a soft, water-dampened cloth and *gently* wipe the surface.

## Installation requirements

The unit may be operated:

- 1) Flat on the its bottom, with lid open.

There are no ventilation requirements. The unit is intended for use in Installation Category II (Portable Equipment), Measurement Category III areas and pollution Degree II Environments where occasional non-conducting condensing pollution can be encountered.

## Pollution degree II

(From IEC 61010-1 3.6.6.2) Only non-conductive pollution occurs. However, temporary conductivity caused by condensation is expected.

## Power requirements

Using the provided AC power cord, connect the unit to a grounded AC power source. The unit's power requirements are 100-240 V AC, 50-60 Hz, 3 A AC maximum current draw.

## Environment conditions/storage

- The unit is for indoor use. If used outdoors, the unit must be protected from rain, snow and other contaminants. Store instrument inside in order to avoid water contamination.
- The unit has been tested for use up to 2,000 m altitude.
- The tester should only be operated in temperatures ranging from 41 to 104 degrees Fahrenheit (5° C to 40° C).
- This unit is for use at a maximum relative humidity of 80% for temperatures up to 31 °C decreasing linearly to 50% relative humidity at 40°C.

## Unpacking the unit

Carefully remove the following items from the shipping boxes.

- EXP4000
- Power Cord

- CT's
- PT's
- Cabling
- Operator's Manual

### Shipment

The EXP4000 is shipped in factory foam-filled containers. Should the tester need to be returned to Baker Instrument Company, an SKF Group Company, we recommend using the unit's original packaging or any equivalent casing that meets the following specifications:

- Corrugated cardboard package containers, double-walled, with a minimum burst test of 275 pounds per square inch and,
- Two to three inches of shock-absorbent material surrounding the entire unit.

**Note:** Cardboard, newspapers, and similar materials are not considered good shock absorbers.



# 1

## EXP4000 tests

### Test domains/testing theory

The EXP4000 utilizes a multitude of tests to determine the power condition, health, load, and energy profile of machines. The following test domains describe the functionality of the instrument along with a description of each test.

#### Testing Capabilities

The EXP4000 is equipped with standard software to initiate testing. Additional software can be purchased if necessary to complete the program the user deems necessary. This additional software is explained in chapters later in this manual. The standard software includes the following domains and tests:

- **Power Quality:** Voltage Level, Voltage Unbalance, Harmonic Distortion, Total Distortion, Power, Harmonics
- **Machine Performance:** Effective Service Factor, Load, Operating Condition, Efficiency, Payback Period
- **Current:** Over Current, Current Unbalances
- **Spectrum:** Rotor bar, V/I Spectrum, Harmonics
- **Connection:** Waveforms, ABC/SYM Comp., Phasors

To view any of these tests, click on the associated domain and then on the associated test. Many of these viewable panels will have results and test log views.

#### Power quality domain

##### *Voltage Level Test:*

- Identifies over and under voltage conditions,
- Compares measured voltage levels with user defined thresholds.

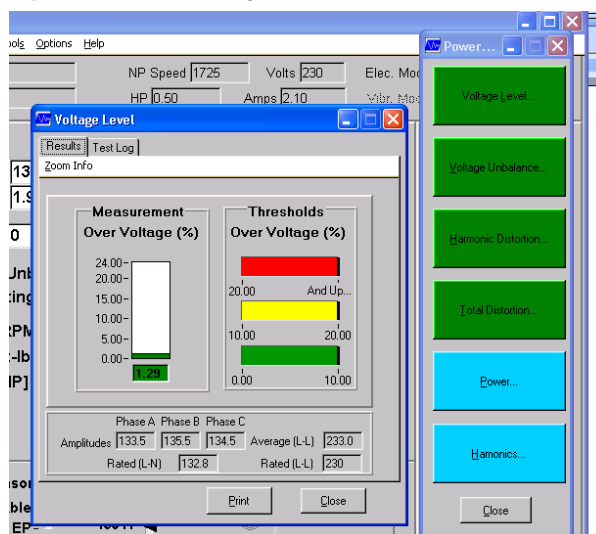

Fig 1-1: Voltage level test within power quality domain

### **Voltage Unbalance Test**

- Examines the single-phase voltage in the motor by calculating its percentage unbalance via NEMA derating,
- Compares the voltage unbalance level with the stored threshold.

A non-balanced voltage condition causes negative sequence currents within the stator, resulting in excessive heat. The voltage unbalance test determines if a non-balanced voltage condition exists in the machine. The EXP4000 utilizes the NEMA derating curve that specifies a maximal load for each type of unbalance.

### **Harmonic Distortion**

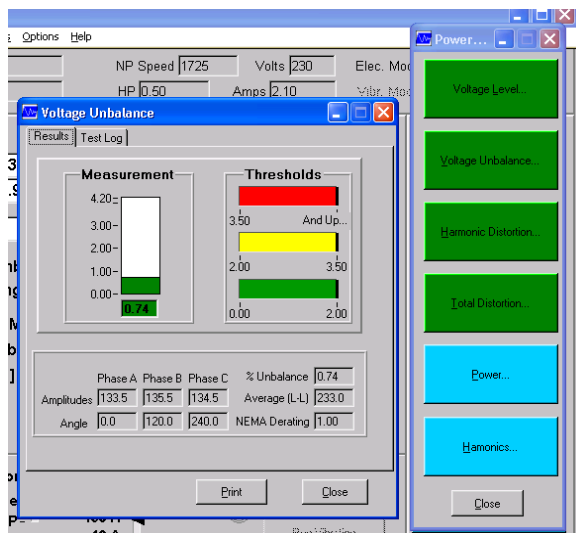

Fig 1-2: Voltage Unbalance within the power quality domain

- Examines the Total Harmonic Distortion of the three single phases to neutral voltages,
- Compares the level of Total Harmonic Distortion to the stored threshold,
- Compares the torque, speed, and average stator current values of machines against previously stored values,
- Alerts the user to values that deviated from previous operation.

Stator current, torque, and operating speed typically describe the health of a machine. For example, maintenance personnel should be alerted if a machine needs to run at a lower speed in order to provide the same torque. The machine may have an issue caused by broken rotor bars, excessive heat, or different voltage conditions.

### **Total Distortion**

Both **Total Harmonic Distortion (THD)** and **Total Distortion (TD)** deal with quantifying the effect of non-fundamental components to the voltage and current waveform. Whereas the Harmonic Distortion focuses on the harmonic content alone, Total Distortion focuses on all non-fundamental components.

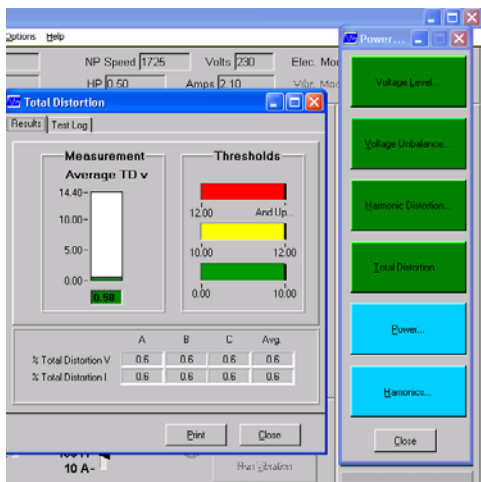

Fig 1-3: Total Distortion within the power quality domain

The commonalities and differences between THD and TD are:

- THD *adds only harmonic components* and divides by the fundamental.
- TD *subtracts the fundamental from the RMS* and divides by the fundamental.
- THD is defined in IEEE and NEMA standard, whereas, TD is not defined in these standards.
- THD delivers reliable results for line-operated machines.
- TD delivers reliable results for all machines.
- For all applications, TD values must always result in higher values than THD.

**Power**

The power window provides information to define power qualities. It displays kW, kVA, and kVAr as well as voltages, currents, power factor, total harmonic distortions and crest factor for voltages and currents. The power details also contain the NEMA derating percentages due to the current and the voltage imbalances.

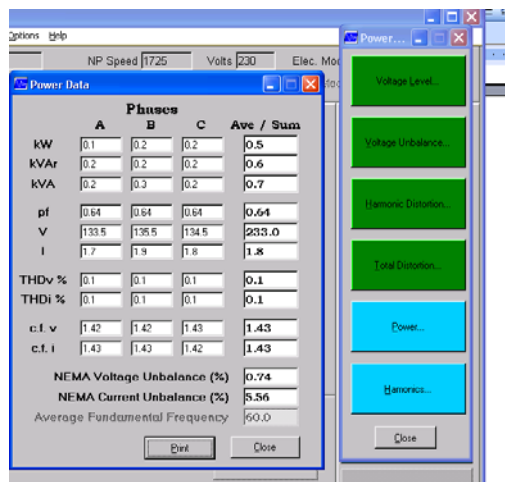

Fig 1-4: Power data within the power quality domain.

## Harmonics

The Harmonic components compare the magnitude of the harmonic components to the fundamental currents and voltages of the system. Bar charts display the distribution of the harmonic content on the different frequency bands for all currents and voltages.



Fig 1-5: Harmonics within the power quality domain

## Machine performance domain

### Effective service factor

- Divides the estimated percentage load by the NEMA derating factor,
- Identifies thermal overloading in the motor.

The service factor test identifies how closely the motor is operating to its effective service factor. The test predicts heat-based deterioration and provides an accurate thermal assessment of the motor.



Fig 1-6: Effective service factor within the machine performance domain.

**Load**

This displays the estimated load for the machine, and compares it with pre-programmable thresholds. A 100% threshold is commonly used since operating above that level may rapidly thermally deteriorate the machine. However, a combination of environmental conditions and criticality of the machine may warrant moving the threshold level to a higher or lower value. For example, additional cooling of the machine may be a reason for allowing a higher load level prior to issuing an alarm.

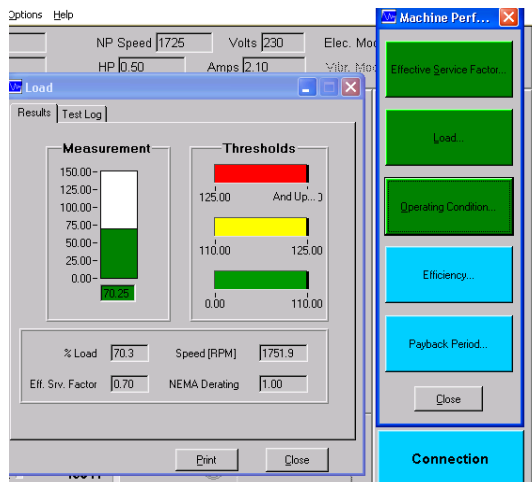

Fig 1-7: Load test within the machine performance domain

**Operating Condition**

Each induction motor has a torque-speed and current-speed characteristic operation curve. These curves will vary their signature if an induction motor’s operation changes from healthy to a faulted condition. For example, increased operation temperature, fluctuating environmental conditions, varied power supply conditions, or broken rotor cages can alter a motor’s operating condition.

Differences in operating condition could indicate two things:

- 1) A change in the operating process,
- 2) A condition that may influence the motor’s operation.

A resultant warning does not necessarily imply a defect in the machine, load or power supply. However, it is important to monitor the machine’s operating condition. Any identifiable changes could affect the future operation of the motor.

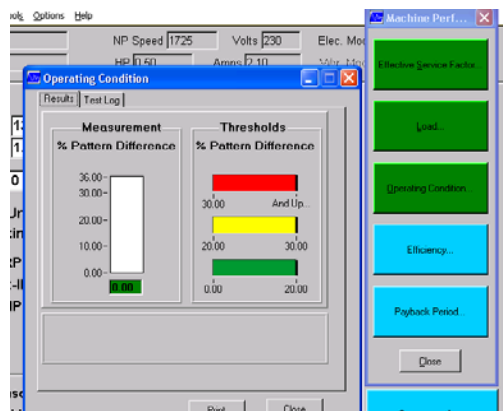

Fig 1-8: Operating condition test within the machine performance domain.

**Efficiency**

Efficiency is the ratio of mechanical output power of the motor to the electrical input power. This can be expressed as:

$$\eta = 100 \left( 1 - \frac{P_{loss}}{P_{in}} \right)$$

Where:

P<sub>loss</sub> = the power that dissipates - mainly heat

P<sub>in</sub> = input power

P<sub>loss</sub> can be seen as the energy in the power bill that is potentially wasted and degrades motor health.

The efficiency test displays the motor’s operating efficiency and previously measured motor efficiencies.

Low results in the efficiency test suggest that motor retrofits may be advisable. A decline in efficiency may indicate an increase in the motor’s operating temperature, causing faster motor degradation.

A manufacturer database with more than 20,000 different motor designs is provided. This database compares existing motors with similar designs that perform at or above EPAct’92. These motors are compared with respect to current operating load point, and their resulting efficiencies. If the efficiency of the motor under test is significantly lower than the target efficiency found on a EPAct motor, a warning or caution flag is issued.

**Note:** If an efficiency warning or caution flag is issued, the following steps should be taken:

- 1) Check that the correct stator and lead line to line resistances have been entered into the Create Motor or Edit Motor panels in the EXP4000 software.
- 2) Motors can operate at low efficiencies because of their design, or poor power conditions. Check that the voltage level is appropriate for the motor tested. Make sure voltage unbalance and voltage distortion are acceptable.
- 3) If, after performing the first two steps, it is found that the motor is performing poorly, further investigate the application using MotorMaster+.

To ensure an accurate efficiency estimation, the test results will only be green, yellow or red, if the stator resistance has been entered for the motor in the Create Motor or Edit

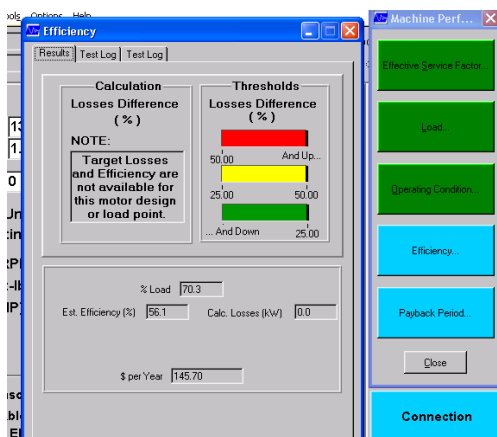

Fig 1-9: Efficiency test within the machine performance domain.

Motor panels of the EXP4000 software.

**Payback Period**

This test searches the database for motors, and compares the energy expenses of the motor under test with higher efficiency motors. Payback period is calculated, based on the compared motor’s list price, the energy savings calculated according to the specified duty cycle of the motor, the entered \$/kWh, and the latest calculated input power of the motor. This test uses the premise that the comparison motor operates, on average, on a load point similar to the one measured. All prices are in USD, so the energy costs have to be specified in USD. List prices are motor manufacturer’s data, and use the US market as a basis. If the EXP4000 is used in other countries, list price should be adjusted.

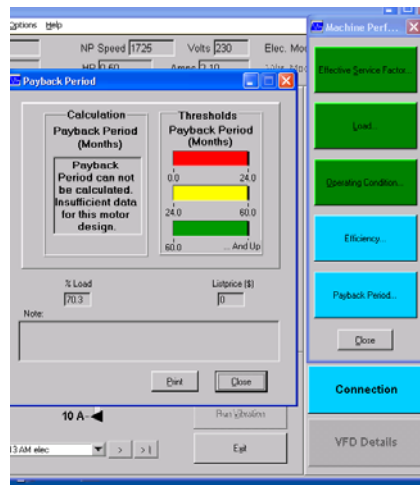

Fig 1-10: Payback period within the machine performance domain

**Current Domain**

**Overcurrent**

- Compares the maximum single-phase current with the nameplate data of the stator current.

Too much current can overstress particular phases in the machine. The overcurrent test

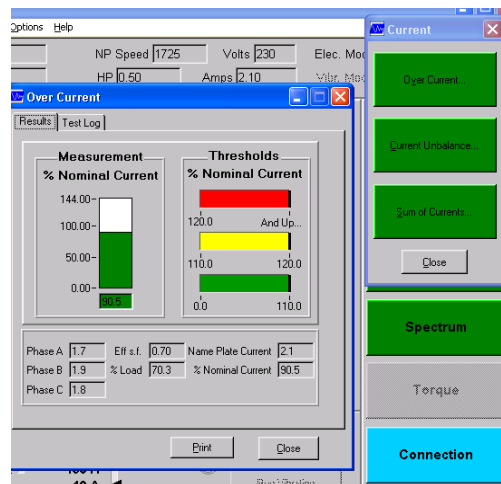

Fig 1-11: Overcurrent test within the current domain

determines if the machine might be drawing more than its rated current on one or more phases. This causes excessive heat and decreasing life of the insulation.

**Current Unbalances**

Unbalanced currents are frequently caused by mildly unbalanced voltages. A common rule of thumb is that voltage unbalance can be the cause of up to eight times larger current unbalances. Machines will also show very large current unbalances under very light, or no load conditions – even when driven by a balanced voltage. These no load current unbalances are common in healthy machines. These current unbalances vanish rapidly when the machine is loaded.

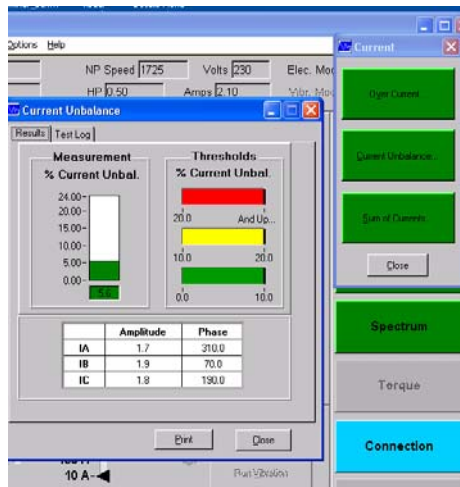

Fig 1-12: Current unbalances within the current domain

**Spectrum Domain**

**Rotor bar/Operating condition**

- Records the relative amplitude of the rotor-bar sideband,
- Compares the rotor cage signature to stored thresholds.

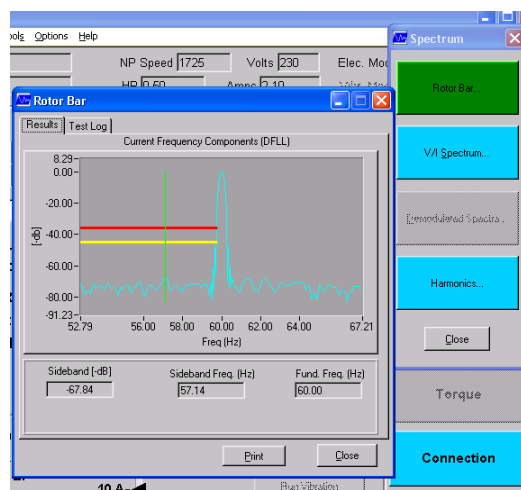

Fig 1-13: Rotor bar within the spectrum domain



The rotor bar test and operating condition test evaluate the overall condition of the machine. Broken rotor bars cause excess heat on the machine, decreasing efficiency, shortening insulation life, and possibly causing core damage.

**V/I Spectrum**

The **V/I Spectrum** window analyzes the frequency spectra of the 3 line-neutral voltage waveforms and the 3 line currents independently of each other. The current spectra have shown to contain information related to the vibration spectra of the machine. It is possible to identify roller-bearing faults by using the mark frequencies option in the right click menu within the EXP4000 software. (see Chapter 3 for more information). It is also feasible to find deteriorating alignment problems, load unbalances, looseness, eccentricity, and cavitation by analyzing these spectra.

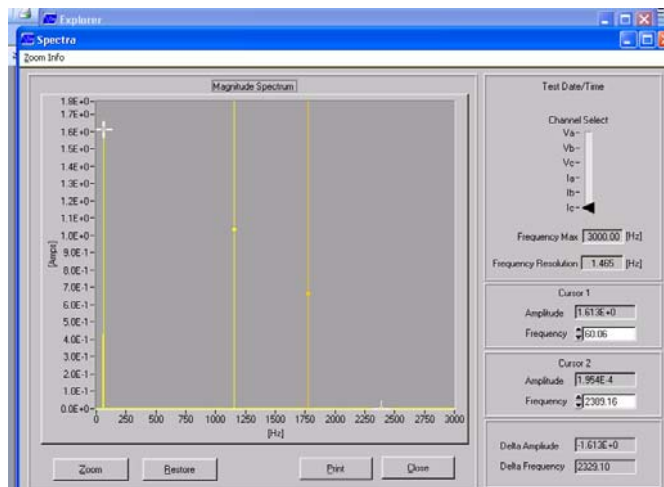

Fig 1-14: V/I Spectrum within the spectrum domain

**Harmonics**

The harmonics components compare the magnitude of the harmonic components to the fundamental currents and voltages of the system. Bar charts for all currents and voltages display the distribution of the harmonic content on the different frequency bands.

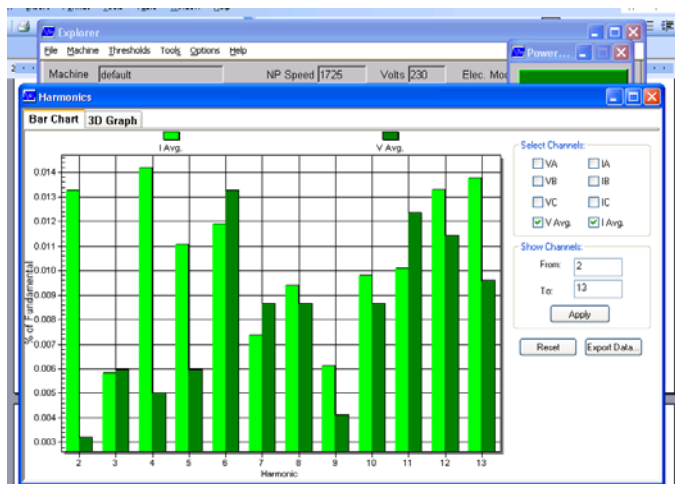

Fig 1-15: Harmonics in spectrum domain

## Connection Domain

### Waveforms

This window shows the waveforms for all three current and voltages for line operated mode. If the EXP4000 is operated in VFD mode (not available in basic software), it shows the voltage and current for phase A.

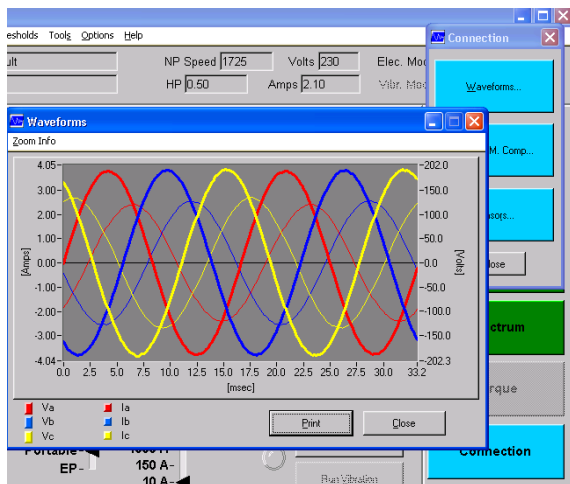

Fig 1-16: Waveforms in the connections domain

### ABC/SYM Comp

The Symmetrical components displays the voltage, current and impedance unbalance and the positive sequence (accelerating) and the negative sequence (retarding). Current, voltage and impedance information.

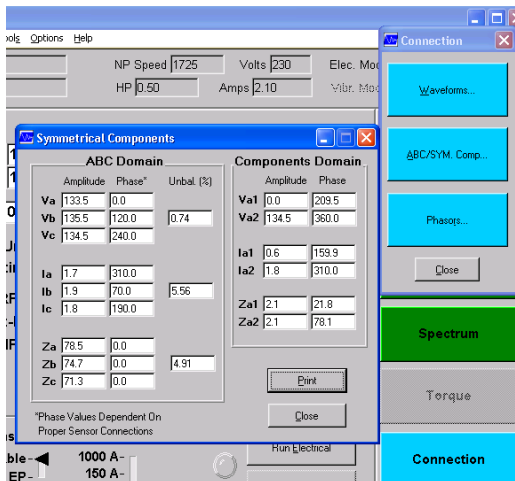

Fig 1-17: ABC/SYM Comp within the connection domain.

### Phasors

The Phasors window shows the *a,b,c* phasors for voltages and current in line operated mode. In VFD Mode (not available in basic software), it shows the instantaneous current phasor versus the instantaneous voltage phasor.

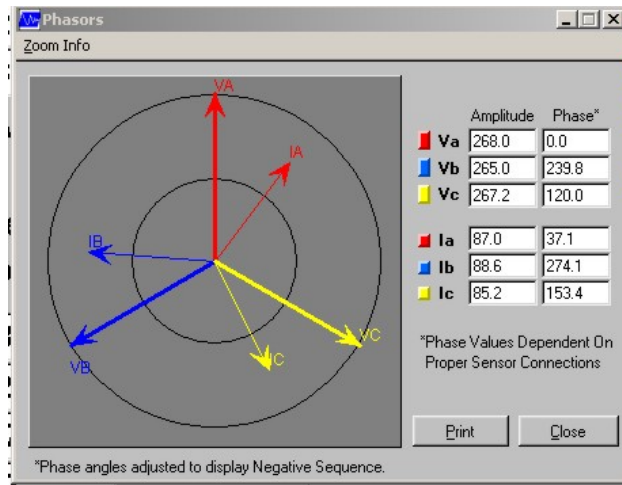

Fig 1-18: Phasors within connection domain



## Declaration of conformity

Manufacturer's Name & Address:

Baker Electrical Instrument Company, an SKF Group Company  
4812 McMurry Ave  
Fort Collins, CO 80525  
USA

Equipment Description: On-Line Motor Monitor  
Equipment Model Designations: EXP4000

Application of Council Directive 72/23/EC on the harmonization of the laws related to Member States relating to electrical equipment designed for use within certain voltage limits, as amended by: Council Directive 93/68/EC and Council Directive 2004/108/EC on the approximation of the laws related to Member States relating to the electromagnetic compatibility, as amended by: Council Directive 93/68/EC. Note: due to the phenomena being observed and the material properties being measured, this equipment does radiate radio frequency energy while in the active test mode.

Referenced Safety Standards:

EN 61010-1

Referenced EMC Standards:

EN 61326:2001

EN 55011 Class A

EN 61000-3-2

EN 61000-3-3

EN 61000-4-2

EN 61000-4-3

EN 61000-4-4

EN 61000-4-5

EN 61000-4-6

EN 61000-4-8

EN 61000-4-11

I, the undersigned, hereby declare that the equipment specified above conforms to the above Directives and Standards.

Signature:

Printed Name: Erik A. Stolz

Title: Electrical Engineer

# Getting started

## Configuring software for motor data

---

### Database Management

Database management is highly important in a good predictive maintenance program. It facilitates organization of periodic maintenance data. The database section of the EXP4000 software allows the entry of identifications to help clarify the location of specific motors. It can maintain multiple databases for organization of overall program maintenance. For example, if a facility has two buildings with a number of motor sights in each, it may work best if there were a database created for each building.

#### *Consequences of not organizing data into databases*

Since the EXP4000 can be configured to store every test it ever performs, an organized structure is needed to facilitate data integrity and usefulness. Also, creating multiple databases allows easier management of file size and archiving.

#### *Plant maintenance:*

It is common for plants to have duplicate processes, with identically named motors in each process. (ex: intake pump) This can cause confusion, since the motors are in different locations, but have the same motor ID. Take steps to make motor ID's unique. For example, the motor ID for process 1 should be intake pump P1 while the motor ID for process 2 should be intake pump P2.

### Database features

The records that are stored by the EXP4000 are linked to each other hierarchically. The principle record, which serves as the base for linking associated records, is the machine ID. Information entered into machine ID and test ID records become part of the database. Like other database information, it can be transferred to other computer programs or other computers.

### Navigating through the software interface

Familiarity with Windows 98se®, Windows NT SP4®, Windows 2000®, or Windows XP® and basic computer skills is assumed. Working with the EXP4000 software requires a general understanding of using multiple windows, a variety of keyboard commands, and a pointer device (mouse).

### EXP4000 software specific features

#### *Grey shaded fields*

Gray shaded fields are generally not editable. Fields with white backgrounds are editable.

#### *Text fields*

Text fields are areas that contain editable words or numbers. To edit text fields, press or click in them and type. The software will prompt the user for missing information required by the EXP4000 if a necessary field is left blank. This is generally in the create motor or edit motor panels.

#### *Arrows and Windows icons*

In the EXP4000, arrows serve two functions. They allow the user to access information that does not fit on the screen or allow the user to change numbers in a text field. For

example, clicking on either the up or down arrow can change a caution threshold for the voltage unbalance test in an electrical test model.

**Numeric Fields**

The two types of numeric fields are input and display. The input fields are required to calculate portion of the result panels or allow entering additional information to the reports. All other numeric fields are display results.

**Starting the software**

To start the EXP4000 software, click on the Explorer icon on the desktop or click on Start, navigate to the Baker Instrument folder and click on the EXP software.

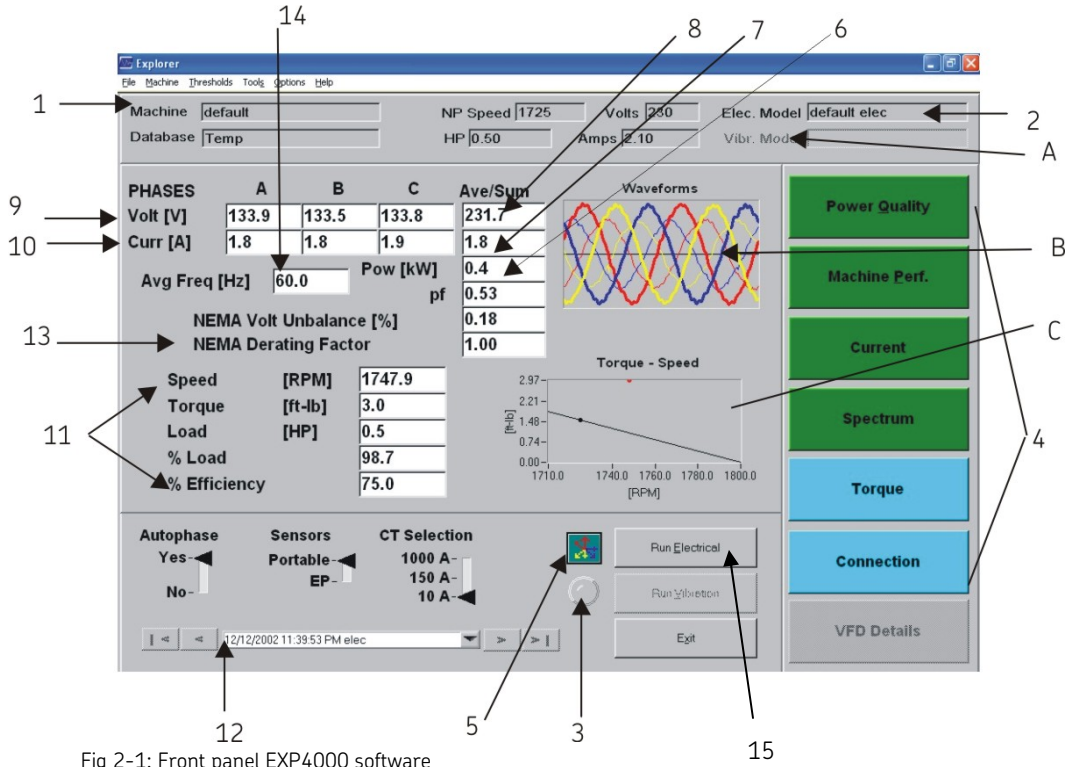

Fig 2-1: Front panel EXP4000 software

- 1) Machine name
- 2) Electric model
- 3) LED indicates activity
- 4) Test domains
- 5) Display phasors
- 6) Total power
- 7) Average line current
- 8) Average line to line voltage
- 9) Line to neutral/ground or line to line Voltage (see Options menu)
- 10) Line current
- 11) Electro mechanical data
- 12) Currently displayed test
- 13) NEMA derating factors
- 14) Average frequency (Hz)
- 15) Run electrical tests

- A) Basic nameplate information of motor under test,
- B) Waveforms display signature of voltage and current,

- C) Displays torque/time (VFD operation mode) or torque/speed (line operation mode)

The main panel consists of three components: the top menu, the numeric fields (center left), and individual test buttons (domains).

**Numerical fields**

6-10): This area displays the single phase to neutral voltages or line to line voltages (depending on the setting in the Options menu), single-phase currents, average, power factors, average current, total electrical input power and average line-to-line voltage.

11) The five numeric fields located in the lower left portion of the center section exhibit the motor’s mechanical and electromechanical operating condition.

12) This text field displays the time of the current test data.

13) The NEMA Unbalance % displays the unbalance level of the voltage and current. The NEMA Derating Factor suggests a derating percentage for the current operating voltage condition.

14) Avg. Frequency displays the average of the fundamental frequency during the data acquisition.

**Domain panel**

The test domain buttons are located on the right side of the main panel. Each test domain button allows access to its specific test results.

Because each threshold equates to a specific color, the EXP4000 assigns a color to the domain and testing domain buttons depending on the test result. *Ex. If the result of the voltage unbalance test fall below the established caution thresholds, the EXP4000 would assign green to the voltage unbalance button.*

**Results panels**

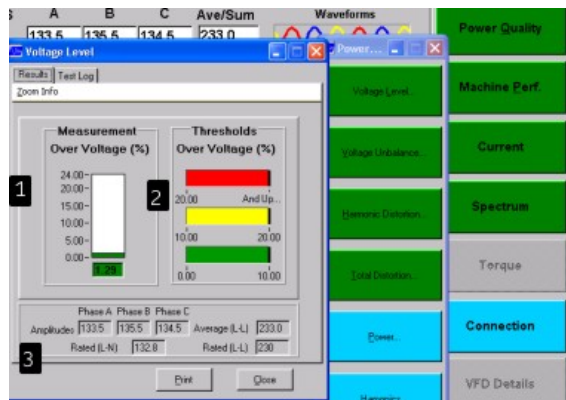

Fig 2-2: Panel Results

- 1) Measurement bar – indicates the severity of the area (test) measured
- 2) Thresholds bar – displays the current threshold level. Each bar has an associated color level. The threshold is user specified in the electric or vibration models.  
 Red = warning  
 Yellow = caution  
 Green = good  
 Blue = no applicable threshold
- 3) Numeric results bar displays relevant test result data, such as the NEMA % derating factor, the % load, and amplitudes for the voltage phasors. The *results* portion allows the

user to access specific test results by scrolling with the left and right arrows in the test field. Each test result contains the date and time for the test and important numeric results.

**Test log panel**

The test log tab displays trending data for the relevant test. It displays the value of the monitored quantity (y-axis) against the test numbers (x-axis). The x-axis shows the number of measurements performed for that particular motor ID.

**Software navigation - finding machines**

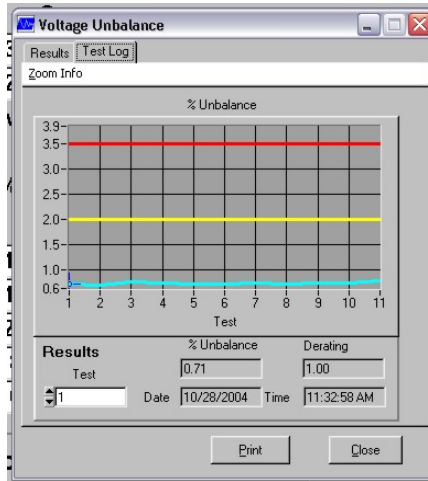

Fig 2-3: Test log panel

Finding machines within the EXP4000 software works similarly to Windows Explorer. To find the machines to be tested simply open the **machine tree** located in the **machine** menu. The highest level is the database name (file cabinet icon). Under each database are locations for each machine (depicted by a factory icon). There can be another factory icon beneath the location icon. This divides the location by buildings, plant or other user derived descriptions. Under these sections are individual machines (motor icon).

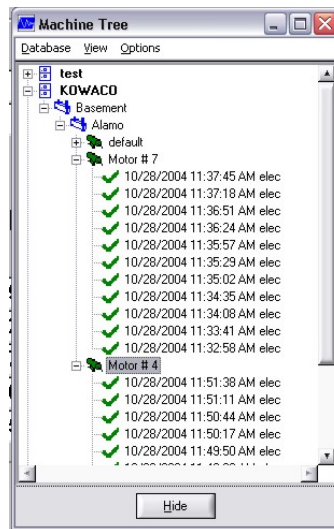





Fig 2-4: Machine tree navigation



- 1) Follow the tree format until the machine is found that needs to be tested.
- 2) Double click on the machine. This will display all associated tests for that machine.
- 3) Highlight the machine to be tested and connect the EXP4000 appropriately (see

chapter  
on

	Database parent directory icon
	Machine location icon
	Machine icon – Icon displays the worst color from the last test on that motor. If no tests have been performed the icons will be white.
	Circle with square waveform for a VFD motor.
Test Icons	
√	Good test (Green)
⚠	Caution flag (Yellow)
X	Bad test (Red)

Connecting the EXP4000 for appropriate connections) and press or click the run electrical to begin gathering data..

### ***Icons Displayed within Machine Tree***

## **Upgrading databases from previous software versions**

Before the EXP4000 software can open a database from previous versions of the software, it must upgrade the database. This upgrade tool will pop up whenever an upgradeable database is opened. It will place the file in a default directory. This directory **must** be a separate database from the one where existing data is stored. After the database is upgraded, it will automatically open in the software. Note that upgrading a database does not delete the old database. It allows expanded capabilities within the new software to be used, while permitting the use of older versions of software on the old database.

There is an executable available that will automatically update all databases at once. Contact Baker Instrument Company, an SKF Group Company for more details.

## Printer configuration

The EXP4000 comes equipped with a set of printer drivers installed. If necessary, more printer drivers may be added. To install a printer, follow the instructions provided in the printer manual.

## Keyboard shortcuts:

- F1 key on the keyboard opens the loaded Help environment.
- F2 key opens the machine tree.
- F3 key operates the Create Machine function.
- F4 key runs the continuous looped acquisition for 10 tests.
- F5 key operates the Run Electrical function.
- F6 key operates the timed looped acquisition function.
- F7 key operates the Virtual Scope
- F8 key displays the Phasors
- F9 key operates the Transient Analysis Dialog
- Ctrl A – About
- Ctrl M – Manual
- Ctrl O – Open Database
- Ctrl N – New Database
- Ctrl B – Create Backup
- Shift F5 – Refresh Machine Tree
- Ctrl F5 – Reload Machine Tree

## Software hints

- Popup panels require the user to immediately interact with dialogs that affect displayed data (loaded or part of a test).
- The time required to load a machine with a large number of tests has been decreased by internally connecting or threading the test logs.
  - o When the machine is loaded but the thread is not completed the message Test log is Loading appears instead of the test log's graphs.
  - o This can cause a perceived lag if the user quickly switches machines or deletes test results from motors with more than 100 stored tests.
  - o This lag time will also be noticeable if the user loads a machine with a large number of tests and then exits.
  - o At this publishing it is recommend keeping the number of tests per motor to a maximum of 2000.

# Basic software overview

## Software overview

---

This chapter will supply the user a general knowledge of how the EXP4000 software is used and navigated. It will step through each of the menus and provide procedures for setting up for data gathering.

### File menu items

The **File** menu allows the user to upload and save motor data files. Under the file menu are the following options: **Database, Print Summary Report, Reports and Exit.**

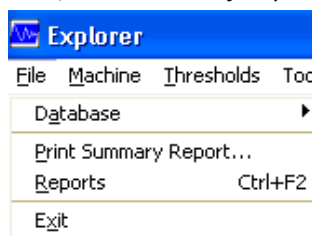

Fig 3-1: File menu

### Database

The **Database** command allows the user to open, create a new, close an existing, or delete a database.

#### *To create a new database:*

- 1) Click on the file menu.
- 2) Click on database and choose new.
- 3) Type the name of the new database in the space available.
- 4) Click ok.

The EXP4000 will then create the database. It will fill in the pertinent information on the screen, including database name and default information. Default information changes are made through the creation and assignment of electrical models in the threshold menu.

#### *To open an existing database*

- 1) Click on the file menu.
- 2) Click on Database and select Open.
- 3) Select the database to open.
- 4) Click and select open or double click on the file to open.

**Note:** Changing databases during operation is allowed by using the open an existing database procedure.

**Note:** Database open will not open an archived database. To open an archived database, either double click it in Windows Explorer, or click Machine Tree, Database, Restore.

#### *To close an existing database*

- 1) Click on the file menu.
- 2) Click on Database and select Close.

- 3) This will automatically close the database.

**To delete an existing database:**

- 1) Close the database.
- 2) Click on the file menu.
- 3) Click on Database (If needed open the folder that the Database files exist in and click on the database file that is to be deleted) and then click on Delete.
- 4) A warning will appear for confirmation on the deletion of the database. Make sure this action is correct. It can not be undone.

**Note:** This will not delete the folder that the Database resides in. In order to delete the folder, right click on the folder and chose delete.

### Print summary report

This option will print an overall summary of the testing done. Additional reports can be printed by clicking the check boxes at the bottom of the summary page. These reports consist of Main Panel, Power Condition Report, Machine Condition Report, Energy

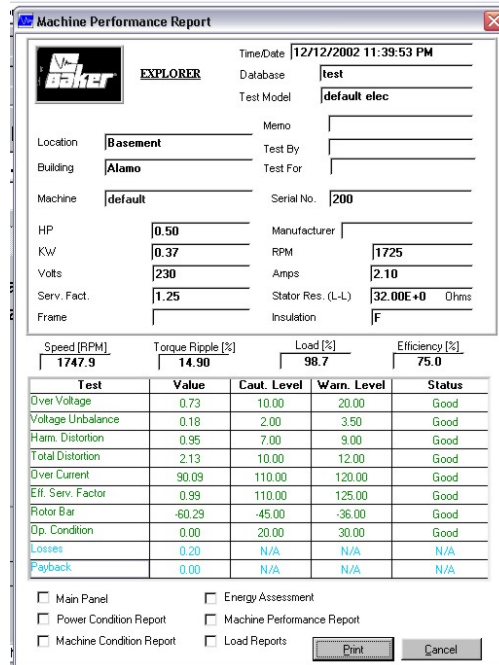

Fig 3-2: Print Summary Report Screen

Assessment, Machine Performance Report, and Load Reports. These items will print the panel page for that specific test.

### Reports

The reports section offers the ability to customize reports to see multiple tests with different filters and trending options.

The Filter On option provides report parameters for Show “Good” Results, Show “Caution” Results, Show “Warning” Results, or allow a Date Range to be used to pick tests for the report.

Options under Select allow the user to select report parameters for All, All Good, All Caution, All Warning, All Warning and Caution or None.

Trending parameters can also be added for more value in reporting. The trending options include, All Machine Results, Selected Results Only and Plot Mode. Plot Mode also includes Line and Point + Line.

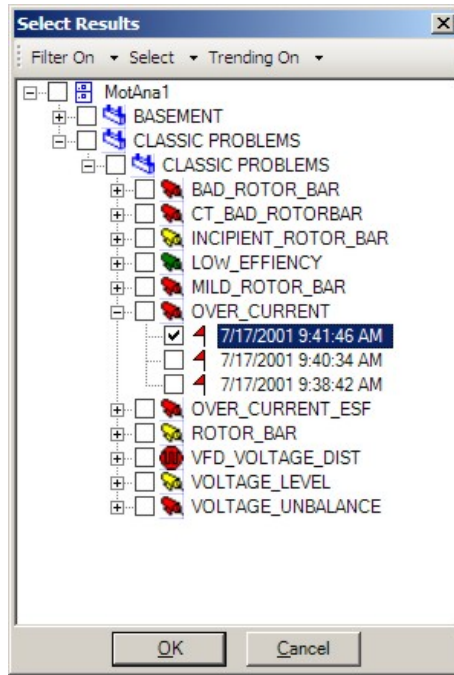

Fig 3-3: Reports selection

A .rtf file is generated by the EXP4000 that can be opened in Microsoft Word, WordPad and several other word processing programs for editing. Remember that report page count will increase dramatically with the addition of multiple tests. This can increase time in report generation and printing.

## Exit

The Exit menu item closes the program.

## Machine menu items

The Motor Menu allows the user to assign, create, edit, or delete particular motors to be tested. Under the Motor Menu are the following options: **machine tree**, **create machine**, **edit machine**, **acquire EP serial number** and **reset EP serial number**.



Fig 3-4: Machine menu

## Machine tree

The Machine Tree allows the user to quickly open databases, perform tests on motors within a database and view different filters to access specific test information quickly and easily. The database menu allows the user to create a new, open an existing or repair a database, along with creating a backup, restoring a backup or synchronizing a database folder. The filter mechanism allows the user to find machines with no tests, with a good rating, with a caution rating, with a warning rating or by date of test. The Options menu offers the ability to browse other drives on the computer to locate databases available to the EXP4000 software. Two options are available from this menu: Set database directory or Set archive database directory.

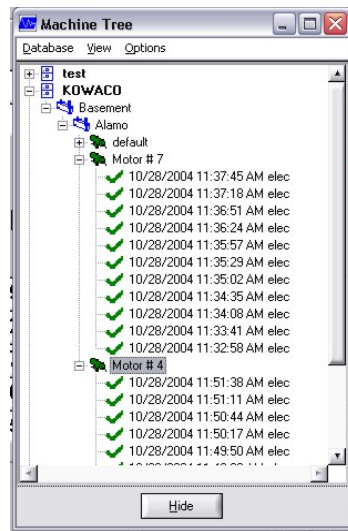

Fig 3-5: Machine tree

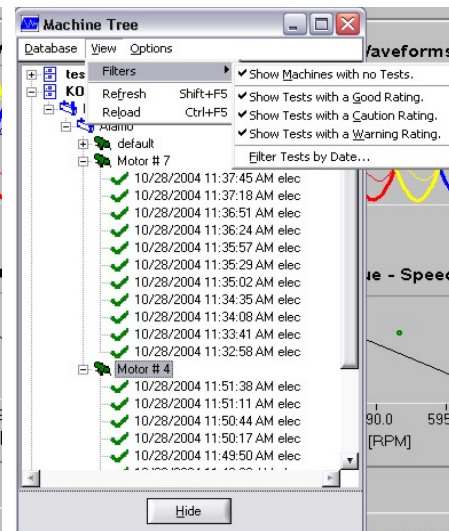

Fig 3-6: Machine tree view

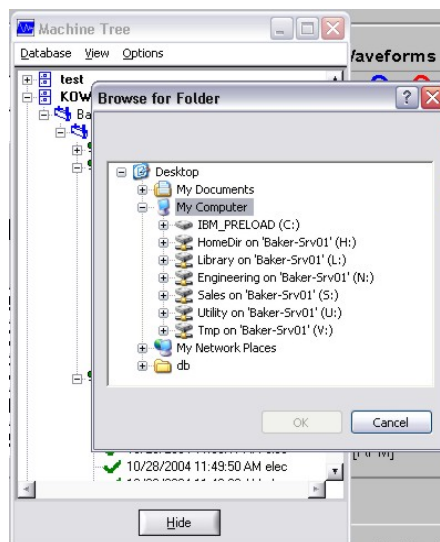

Fig 3-7: Machine tree options section

## Create machine

The Create Machine option generates a new machine ID, which is required to run electrical or vibration tests. The Create Machine properties panels have four sub-panels or tabs. The Name Plate and Machine Information tabs will remain red when required information is needed. All fields in red must be filled with appropriate data for the EXP4000 software. Fields marked in yellow can affect the results the EXP4000 can generate. Remember the more information that is accurately entered, the more applicable the results will be. The software will prompt for missed information. The EXP4000 software also includes IntelliCreate technology, that checks the applicability of entered data. IntelliCreate identifies the majority of typos and omissions of data fields during machine creation.

### Name plate

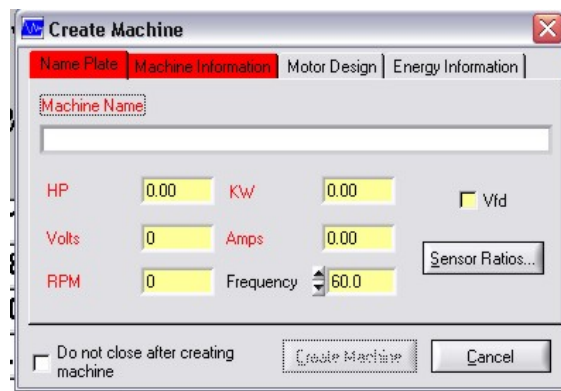

Fig 3-8: Create machine name plate tab

Machine Name, HP, Volts, RPM, KW and AMPS are required data on this tab. Appropriate KW data will be automatically entered to match the machine.

- 1) Click in Machine Name and give the motor an appropriate name per the process that it is running.
- 2) Tab between the other views.
- 3) Notice that some items will automatically calculate and apply the appropriate value.

### Sensor ratio

When connecting to the secondaries of CT's and PT's in the field, the **sensors ratios**

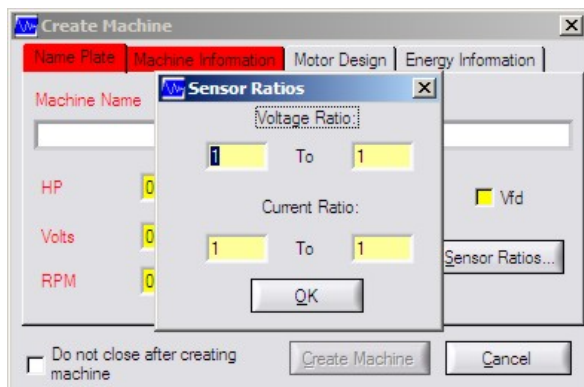

Fig 3-9: Create machine: Sensor ratios

button opens a Sub-panel from the Name Plate Tab.

**Note:** This needs to be set up with the ratios of the PTs and CTs whenever a motor is tested at the low voltage side of PTs and CTs.

**Machine information**

The only required element in the machine information section is the Machine Name. This will automatically filled from the Name Plate section. The location and building will be filled in from the default database items. All other information is optional; however, it can be important for tracking instrumentation and report generation.

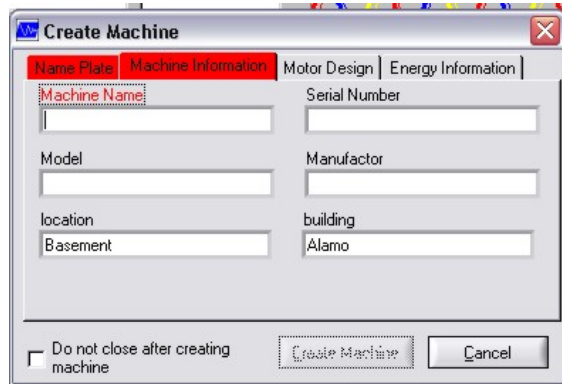

Fig 3-10: Create machine: Machine information

**Motor design/Energy information**

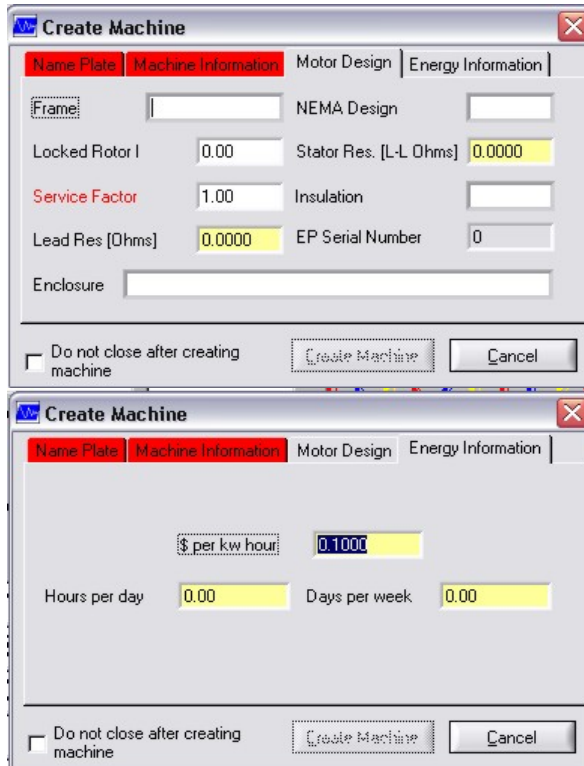

Fig 3-11: Create Machine: Motor Design/Energy Information sections

The information entered into the motor design and energy information sections of the create machine section are optional items except for Service Factor, which will be



automatically calculated from previous input information. Remember the more information that is entered, the more accurate results will be.

## Edit machine

The Edit Machine menu items allow changes to any new Machine ID's information. The same screen views are available as for creating a machine. Edit any item that were entered incorrectly or incompletely.

**Note:** In order to avoid the creation of erroneous data in the baseline, the EXP4000 does not allow changing some nameplate data fields after data has been taken and stored. In order to edit these fields, it is necessary to create a new machine ID. The data previously taken cannot be moved to the new machine ID, so testing will have to be repeated.

- 1) Locate the machine that needs to be edited within the Machine Tree.
- 2) Click on the Edit Machine function in the Machine menu. The Edit machine dialog boxes will appear. It will show the information.
- 3) Edit the appropriate fields and click Apply.

### Delete a machine

- 1) Click the machine tree function under Machine menu.
- 2) Scroll through the list of machines and find the correct machine to be deleted.
- 3) Highlight the machine and hit delete on the keyboard.
- 4) A caution box will appear to verify if the deletion is correct.

**Note:** this action permanently deletes the machine and all associated tests. It cannot be undone, so verify that this action is correct prior to deleting.

## Acquire EP serial number

The Acquire EP Serial Number permits association of a particular EP with a Motor ID. This will enable the direct storing of data taken via an EP, without the need of selecting the motor prior to testing.

- 1) Click on Acquire EP Serial Number.
- 2) The software will notify you if the procedure was successfully completed.

## Reset EP serial number

An EP can be unassociated with a machine in order to re-associate the EP to a newly installed machine.

- 1) Click on Reset EP Serial Number. This will unassociated the EP .
- 2) To re-associate another machine with this EP, do the Acquire EP Serial Number procedure.

## Thresholds menu

An electrical test model is a set of thresholds used as a guide against which the machines will be tested. The EXP4000 compares test results with the electrical model's predetermined tolerances.

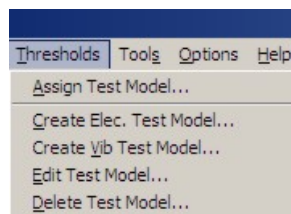

Fig 3-12: Threshholds menu

## Assign test model

The assign test model option allows the designation of an electrical test model with which to test motors.

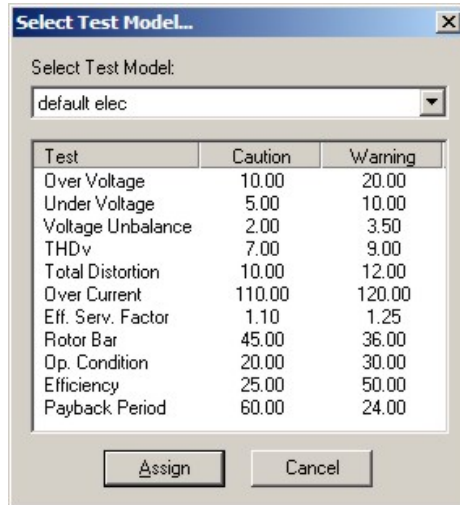

Fig 3-13: Assign test model

- 1) Click on the Thresholds menu.
- 2) Click on Assign Elec. Test Model.
- 3) Select a test model by clicking on the Select Test model drop down box.
- 4) Once the desired test model is found, click Assign.

## Create elec. test model

The **create elec. test model** command allows setting of thresholds for electrical tests. When this menu item is clicked information is requested for caution and warning test levels. This is useful for creating templates for motors in different service environments.

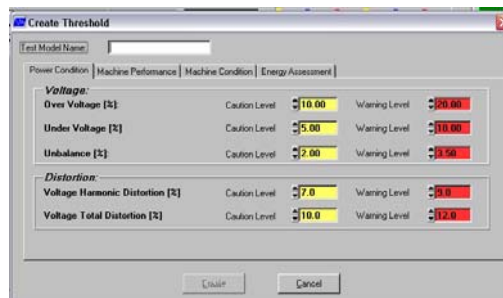

Fig 3-14: Create Elec. Test Model

- 1) Click on Thresholds menu.
- 2) Click on Create Elec. Test Model.
- 3) Type a name for the test model in the box.
- 4) For each test, enter the caution level and warning level thresholds. Adjust thresholds by clicking the up and down arrows or by entering numbers in the text field. Note: For the Voltage Level test, enter caution and warning level thresholds for over and under voltages independently from each other.
- 5) Click Create. This will save the new test model and return to the main menu.

## Edit test model

The Edit Test Model menu item allows editing of the thresholds for a particular electrical test model.

**Note:** Editing the default Test Model is not allowed.

- 1) Click the Thresholds menu.
- 2) Click the Edit Test Model.
- 3) Click on the arrow to the right of the Select Test Model text field by scrolling through the test model list.
- 4) Click Edit. The Edit Test Model panel will appear.
- 5) Make corrections or changes as needed.
- 6) Click on Save to complete the edits.

## Delete test model

The **delete elec. test model** option allows deletion of any particular electrical test model which is not currently assigned to any **motor ID**, other than the **default Test Model** (which can not be deleted).

- 1) Click the Thresholds menu.
- 2) Click the Delete Test Model.
- 3) Click the arrow to the right of the Select Test Model text field. Select the desired test model by scrolling through the test model list.
- 4) Click Delete. A warning window will appear to verify that this operation is appropriate. If it is, click Yes. The test model will be deleted.

## Tools menu items

The Tools menu has a number of items that will assist in monitoring machines.

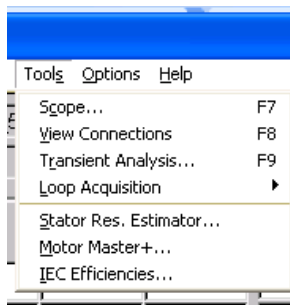

Fig. 3-15 Tools menu

### Scope

Clicking on the **scope** menu displays a virtual oscilloscope. The virtual scope displays currents, voltages, or acceleration as a function of time and frequency. It provides information on:

- Voltage phase to ground
- Phase to phase voltage
- Phase current
- Vibration signal

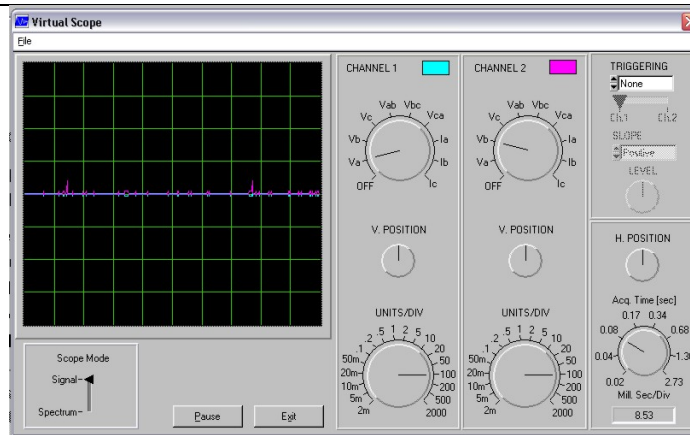

Fig 3-16: Virtual scope

The **triggering** function allows waveforms to appear stable on the scope by acquiring data at a particular point. The triggering function establishes a value within a range of the positive and negative peaks. For example, a waveform oscillates from  $-5\text{ V}$  to  $+5\text{ V}$ . If the trigger level is established at  $2\text{ V}$ , ascending slope, the scope will begin to acquire data at  $2\text{ V}$  while the data is increasing.

- The Scope mode displays test results as a function of time or frequency.
  - Signal = time
  - Spectrum = frequency
- The **channel** knobs displays test results for a specific phase in volts, currents, or vibration.
- The **units/div** knob allows a specific number of volts or amps to be displayed per division.
- The **sec/div** knob specifies the amount of time for the horizontal divisions. For example,  $1\text{ ms}$  equals  $1$  millisecond per division.
- The **V position** knob changes all displayed waveforms up or down.
  - The **H position** knob moves all displayed waveforms left or right.
- The **pause** button stops the digital scope from acquiring in a loop, and holds the last acquired condition.
- Under the file menu there are several options for the scope. The **save waveforms** option make possible to place the displayed data into a text file. This can then be used with other software for further evaluation.
  - The **load waveforms** option allows the display of saved data.
- Use the **print graph** function to print the currently displayed graph on the screen.
- The **print panel** option will print the whole panel. This includes the right portion of the panels, which show knob settings..
- Click **exit** to exit the scope tool.

## View connections

This view displays connections currently used. The Check Connections light will illuminate red if the connections are incorrect. When the connections are correct, the Check Connections light will be green.

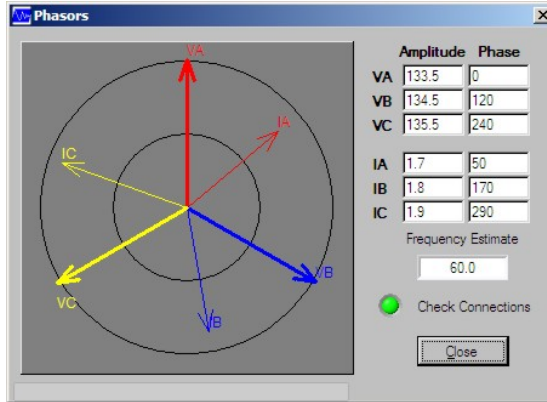

Fig 3-17: View connections

### Transient analysis

The **Transient analysis** mode permits capture of startup transients via voltage and current vs. time and torque vs. time.

Within Transient Analysis a submenu is available. Options are **File and Zoom Info**. Under **File** there are three items, **Delete Test Result**, **Output Raw Data to File** and **Output RMS Data to File**. The **Zoom Info** option gives directions on how to use the tool on these graphs.

The **Print** option prints either plot.

The **Trigger** source allows the choice between triggering on Voltage (V), or on Current (I) source.

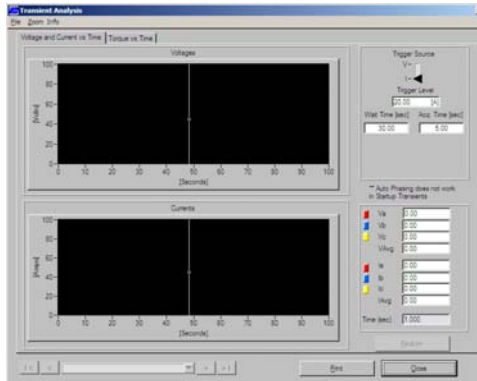

Fig 3-18: Transient Analysis Torque vs. Time

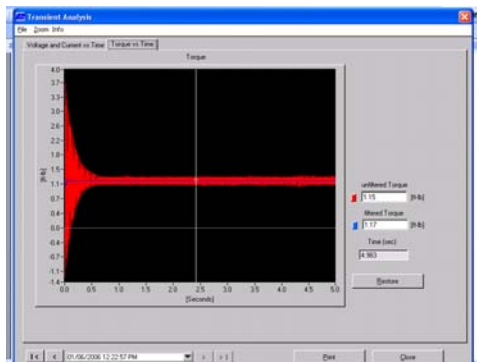

Fig 3-19: Transient analysis Torque vs. time

The **Trigger level** field specifies at what Amps or Voltage the Triggering is to occur.

When clicking on any point on either the voltage or the current displays, a marker depicts the point in both panels, and the voltage and current data are displayed for that instant in time. The same methods of control work on the second tab of the **transient analysis**. The **torque vs. time** window displays two different views of the instantaneous torque. In red, the unfiltered torque displays the highest level of dynamic behavior of the airgap torque as calculated from currents and voltages. The blue line, Filtered Torque, shows the same, but with a lower dynamic resolution. The blue line can be viewed as a short time average of the red line; and it describes the fundamental behavior of the torque versus time; while the unfiltered red line can be viewed as the highest level of dynamic torque display.

## Loop acquisition

The option **loop acquisition** contains two submenus, **continuous** and **timed loop acquisition**. **continuous mode** will run as many consecutive tests as specified, with no interval between tests.

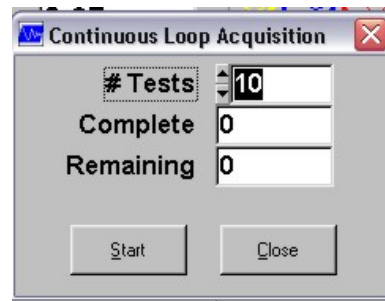

Fig. 3-20: Continuous Loop Acquisition

**Timed mode** allows the user to specify a number of continuous looped acquisitions, to be repeated in intervals between tests that are user specific.

The user can choose the start time to either be immediate, or at a specific time and date. Ending the testing can be similarly chosen.



Fig 3-21: Time looped acquisition

## Stator resistance estimator

The Stator Resistance Estimator is necessary to make the efficiency estimation as accurate as possible. Fill in the necessary information and click on Estimate Resistance to obtain this calculation. Then click on Close and this calculation will be used on the current machine. In the field if a Kelvin bridge is not available, this will give a rough estimation of the resistance of the machine. The value for stator resistance can be overridden in the Machine, Edit Machine, motor design screen.

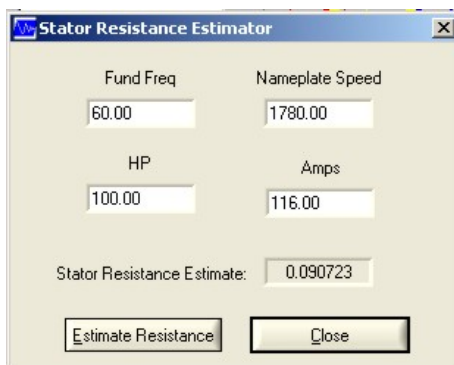

Fig 3-22: Stator resistance estimator

### Motor Master +

- Used in USA only.
- Requires additional software.
- Allows the identification of inefficiently operating motors.
- Can calculate wasted energy and money savings
- Assesses pay back periods for replacing motors with more energy efficient equipment.



Fig. 3-23: Voltage and Current vs. Time

### IEC efficiencies

The **IEC efficiencies** option shows European Eff from the IEC standard table. This shows the different efficiency classes as a function of the motor's rating, and full load efficiency. The second tab, the D.O.E. table, shows the minimal nominal efficiency for motors in accordance to EPAct 92, and [1].

**EC Efficiencies**

TWO-POLE				FOUR-POLE			
kW	Efficiency (%)			kW	Efficiency (%)		
	Eff 1	Eff 2	Eff 3		Eff 1	Eff 2	Eff 3
1.1	82.8		76.2	1.1	83.8		76.2
1.5	84.1		78.5	1.5	85		78.5
2.2	85.6		81	2.2	86.4		81
3	86.7		82.6	3	87.4		82.6
4	87.6		84.2	4	88.3		84.2
5.5	88.6		85.7	5.5	89.2		85.7
7.5	89.5		87	7.5	90.1		87
11	90.5		88.4	11	91		88.4
15	91.3		89.4	15	91.8		89.4
18.5	91.8		90	18.5	92.2		90
22	92.2		90.5	22	92.6		90.5
30	92.9		91.4	30	93.2		91.4
37	93.3		92	37	93.6		92
45	93.7		92.5	45	93.9		92.5
55	94		93	55	94.2		93
75	94.6		93.6	75	94.7		93.6
90	95		93.9	90	95		93.9

**IEC Efficiencies**

Motor Horsepower/Standard Kilowatt Equivalent	Nominal full load efficiency					
	Open motors			Enclosed motors		
	6	4	2	6	4	2
1/75	80.0	82.5		80.0	82.5	75.5
1.5/1.1	84.0	84.0	82.5	85.5	84.0	82.5
2/1.5	85.5	84.0	84.0	85.5	84.0	84.0
3/2.2	86.5	86.5	84.0	87.5	87.5	85.5
5/3.7	87.5	87.5	85.5	87.5	87.5	87.5
7.5/5.5	88.5	88.5	87.5	89.5	89.5	88.5
10/7.5	90.2	89.5	88.5	89.5	89.5	89.5
15/11	90.2	91.0	89.5	90.2	91.0	90.2
20/15	91.0	91.0	90.2	91.0	91.0	90.2
25/18.5	91.7	91.7	91.0	91.7	92.4	91.0
30/22	92.4	92.4	91.0	91.7	92.4	91.0
40/30	93.0	93.0	91.7	93.0	93.0	91.7
50/37	93.0	93.0	92.4	93.0	93.0	92.4
60/45	93.6	93.6	93.0	93.6	93.6	93.0
75/55	93.6	94.1	93.0	93.6	94.1	93.0
100/75	94.1	94.1	93.0	94.1	94.5	93.6
125/90	94.1	94.5	93.6	94.1	94.5	94.5
150/110	94.5	95.0	93.6	95.0	95.0	94.5

Fig 3-24: IEC Europe and IEC DOE efficiency tables

### Options menu items

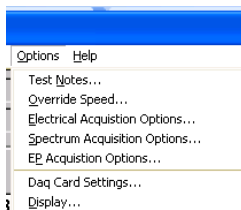

Fig 3-25: Options menu

### Test notes

The test notes command allows creation of memos and identifies who tested the motor ID.



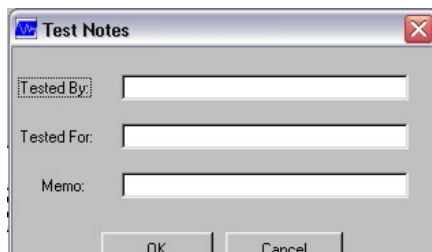

Fig 3-26: Test Notes

## Override speed

The override speed function is used to manually enter the operating speed prior to performing electrical measurements.

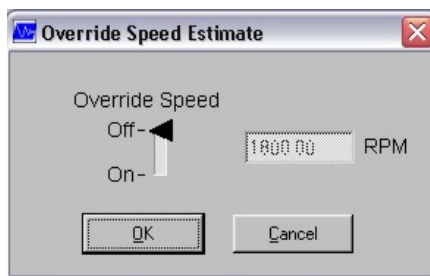

Fig 3-27: Override Speed Estimate

## Electrical acquisition options

- Increase resolution on Rotor Bar test. For low slip motors, it will increase the probability of finding a problem.
- **Note:** should be used in constant load application.

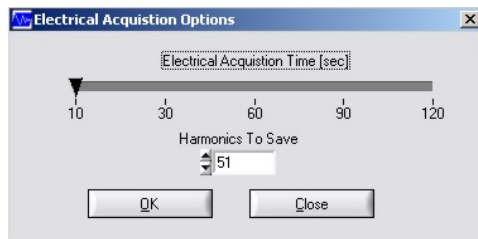

Fig 3-18: Electrical acquisition options

## Spectrum acquisition options

Control data acquisition settings for the frequency spectrum analysis from this panel. The left tab, **max. frequency (Hz)**, sets the maximal displayed frequency of the acquired signal. On the right, the **FFT lines** tab controls the numbers of frequency bins (lines) that are displayed in the initial spectrum display.

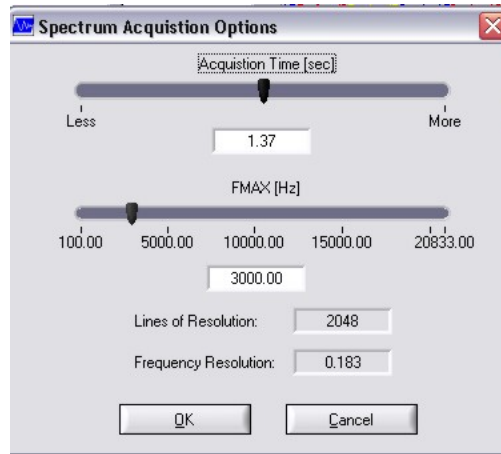

Fig. 3-29: Spectrum acquisition

## EP acquisition options

- If the EXP4000 is being used for quality control to test motors the EP can be adapted to a one EP for many machines instead of a one to one relationship.

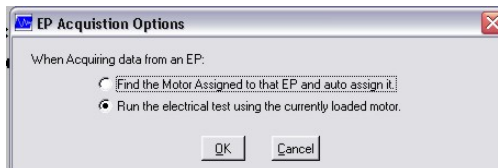

Fig 3-30: EP Acquisition Options

## Daq card settings

This option is a built-in advanced debugging tool, which changes the operation of the EXP4000. Please call Baker Instrument Company, an SKF Group Company for further information on its usage.

## Display options

The **display options** menu item allows changes to the looks of the EXP4000 software. The first field switches between the U.S. Customary and Metric modes. The differences lie in that U.S. Customary prefers Hp and lb-in for output power of the motor and torque, respectively, while the metric system chooses to display kW and Nm for the same physical quantities. The currency ring can change between displaying \$ and £ for the monetary values. The last field allows switching between displaying phase voltages to line voltages.



Fig 3-31 Display Options



# Torque software overview

## T3000 torque analysis software

The T3000 torque analysis software allows the user to access the torque domain. If enabled, the torque domain supplies the demodulated spectrum, torque ripple and torque spectrum.

### Spectrum domain – demodulated spectrum option

#### *Demodulated spectrum*

With this software the EXP4000 calculates the 3D – demodulated spectrum of the torque signature. With the channel control, this signal can be changed from torque to current or voltage of any one of the phases. The demodulated spectra tool analyzes the dynamic behavior profile of the motor load system.

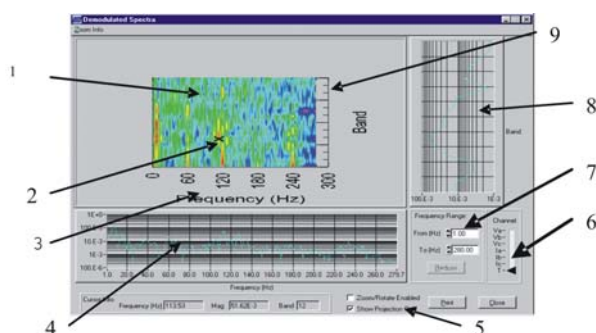

Fig 4-1: Demodulation zoom in

- 1) 3D demodulated spectrum
- 2) Marker
- 3) Frequency of interest
- 4) Frequency of spectrum
- 5) Viewing controls
- 6) Channel selector
- 7) Frequency range
- 8) Band projection
- 9) Band scale

The main information of the demodulated panel is the **3D demodulated spectrum** and the **Frequency spectrum**. The **Marker** can be moved by a mouse drag and drop operation. The mouse cursor changes from its normal shape to a hand with pointing index, when the cursor is above the marker. By keeping the left mouse button clicked, and moving the mouse cursor over the point of interest and releasing the button will move the marker to the desired location. The marker's location is important, because it is the location at which two projections are plotted to the graphs and to the right and bottom of the 3D plot. It shows the relative amplitudes of the marker's frequency for the different bands of AM demodulation. The bottom plot shows the frequency cut performed at the marker's location Band. A band is defined as a frequency that is center to the AM demodulation. More

information on AM demodulation can be found in a multitude of textbooks on fundamentals of signals, linear systems, transform analysis and communication theory [j-].

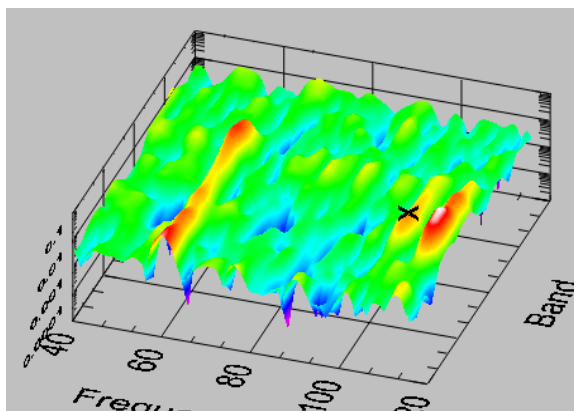

Fig 4-2: Demodulation zoom in

The **Frequency** scale at the bottom of the 3D graph has the same meaning as the scale to the bottom of the projection. Typically, frequency components of interest are read on these scales. The **Channel** selector position runs the demodulation algorithm for voltage, or current of the phases A, B, or C; or over the default torque setting. The graph amplitude is displayed in volts, amps, or Newton meters. The **Frequency Range** setting allows for zooming in or out. The scale **Band** identifies the different AM demodulation bands that have been analyzed via the DFLL.

The **Viewing Controls** allows changing of the settings on the 3D graphs. Disabling the **Projection Only** view and enabling the **Zoom/Rotate** options, allows changes to viewing of the 3D graph. The particular keys for zooming, panning and restoring, are described in the zoom info bar located in the result panels.

## Torque domain

Two tests are available within the torque domain: Torque ripple and torque spectrum.

**Torque ripple**

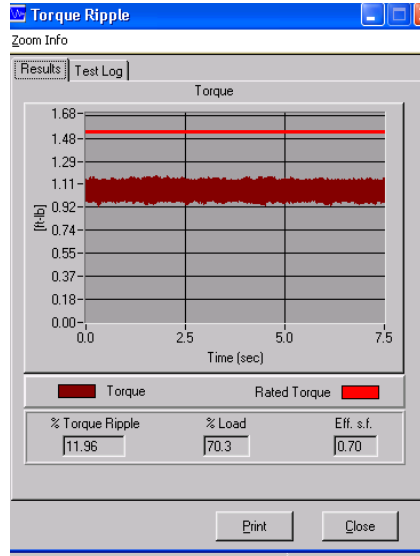

Fig 4-3: Torque ripple within the torque domain

**Torque spectrum**

Clicking on torque spectrum, opens a window that shows the frequency spectra of torque. Scales Newton meter or foot-pounds (lb-ft) for torque. Metric versus US customary settings are changed under Options, Settings. Zooming is possible by identifying a frequency range with the two yellow markers. These markers are moved with the mouse by dragging and dropping. Once the window is identified, operating the Zoom button will recalculate the frequency components of the signal located between the yellow vertical markers.

The recalculation is done via the DFLL [h]. This means that the narrower the window between the markers is, the higher the resolution.

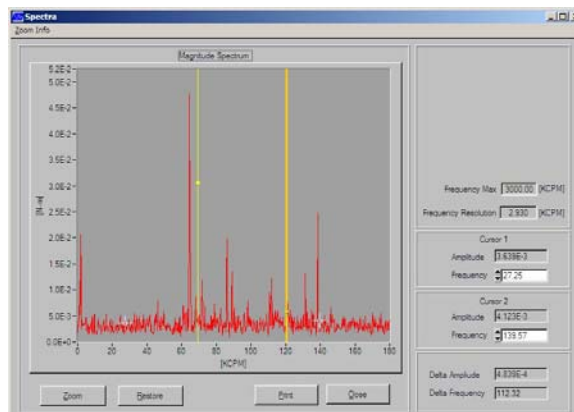

Fig 4-4: Torque spectra within torque domain

To restore to the maximal bandwidth display, click on restore.

Two white cross markers can be moved via mouse point and click. They attach to the displayed frequency spectrum. The marker's location is displayed in the Cursor 1 and Cursor 2 fields. The cursor to the left is defined as Cursor 1 and marks the lower frequencies. The difference in amplitude and frequency between both is shown in the fields Delta Amplitude, Delta Frequency.

### Right Click menu

By clicking the right mouse within the graph opens the following floating menu.

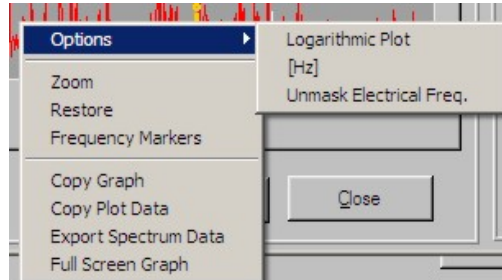

Fig 4-5: Right Click Menu

Options, has a set of three toggle settings. The first one switches between Logarithmic Plot and Linear Plot for the y-axis scale. The second choice, Units in KCPM or Units in Hz enables switching the x-axis scaling from and to Hz or KCPM (1,000 CPM) settings. The last choice of this sub-menu allows to chose between Mask Electrical Freq. to Unmask Electrical Freq. settings. Masking electrical Frequencies effectively cuts the peaks in the frequency spectrum, which are caused by the known electrical fundamental frequency. This setting erases the saliency of the electrical fundamental peak, and its harmonics.

The Zoom and Restore options cover the identical functions as the Zoom and Restore buttons of the Spectra panel.

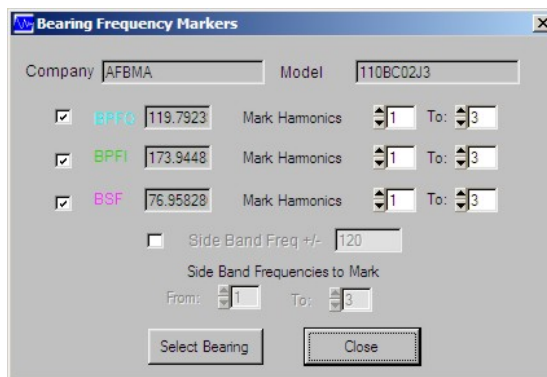

Fig 4-6: Bearing frequency markers

Frequency markers allow the addition of bearing frequency information. To set the appropriate bearing frequency click on frequency markers and then select bearing. From the drop down lists choose the company and model number of the bearing. If the bearing is not available, click on create bearing. Input the needed information. If the BPFO, BPFI or BSF frequencies are not known, click on Estimate Frequencies and input the number of balls the bearing has and the frequencies will automatically will be estimated. After all information is entered click ok. Select which frequency markers are needed (BPFO, BPFI and BSF) and color associated lines will appear on the graph. Side band frequencies can also be added to the graph by selecting the



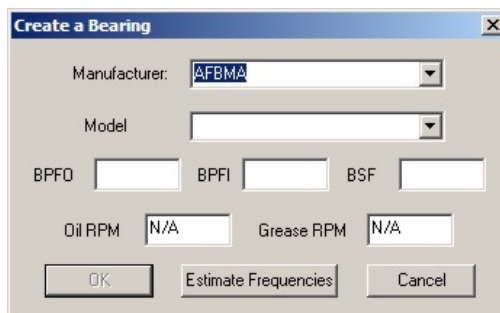

Fig 4-7: Create a bearing

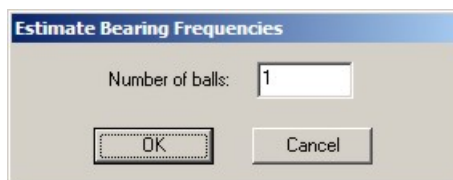

Fig 4-8: Estimate bearing frequencies

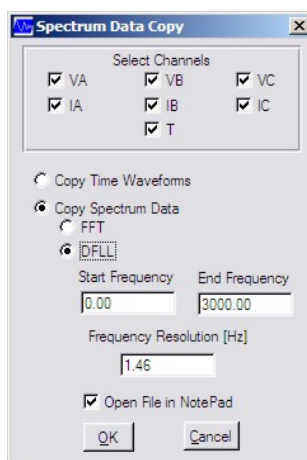

Fig 4-9: Spectrum data copy

checkbox. These sidebands can be increased or decreased by using the up/down arrows associated with the sidebands.

Copy graph and copy plot will copy data that can be placed in reports or saved to files.

Export data copy will export all numerical data for the spectra to a WordPad file. Select the data that is needed by clicking in the checkboxes and radio buttons to customize the data file.

Finally, by clicking on full screen graph, the user can view an enlarged graph. To return to regular screen, press Esc.



# VFD software

## VFD3000 (VFD analysis software)

---

The use of variable frequency drives (VFD's) are widespread. These types of rotating machinery are highly useful; however, are difficult to analyze for problems due to their variable nature.

### Operation details

The VFD Details window can only be activated, if the measurements were taken in VFD mode. This window displays the dynamic behavior of voltage level, torque, frequency and speed as a function of time.

### VFD mode

The EXP4000 has 2 different modes of operation: VFD, and non-VFD (60Hz or 50Hz) line operated. For these two modes the connection requirements are slightly different. In VFD mode, the Autophasing feature is off. Correct phasing of CT's with respect to voltage leads needs to be ensured by the operator. Each CT must be connected to the correct phase and with the correct polarity. In other words, if two or three CT's are connected to the wrong phases, the results displayed by the EXP4000 will not be correct. Or if one, two or three of the CT's are hooked up with the wrong polarity (arrow pointing in the wrong direction) then the results cannot be correct.

The following table displays issues and their corresponding solutions.

**Note:** If in VFD mode, the Voltage Level is only displayed as a function of time. This mode of operation is not a pass/caution/warning mode any longer. All voltage level tests performed in VFD mode will lead to a blue color.

Issue	Possible Cause	Action
Note that V- and I- sequence do not coincide	Voltage is connected in abc and current in acb sequence, or vice versa.	Swap two CT connections. (Example: swap red and yellow CT positions)
Speed negative, Torque negative, kW positive, pf positive	Voltage and currents are connected acb with respect to electrical hardware. Displays that the VFD is turning in negative direction, motoring.	To obtain positive rotation data, exchange Voltage clip from red to yellow, and exchange CT from red to yellow. Keep orientation of CT the same.
Three power factors (Details, Power) are negative or load is very wrong (FAR too high or	CT's are Facing the wrong direction or Connected to the wrong phase	Turn the three CT's around. (Reverse direction of arrow) Exchange cyclical locations of CT's (red to yellow, yellow to blue, blue to red). If results still not correct, perform this step one more time. Otherwise check a)

FAR too low)		
Speed negative, Torque positive (or vice versa)	Connected to a generator and not to a motor CT's polarity is wrongly connected	Everything is fine Turn the CT's around. (Reverse direction of arrow)

### Phasors

In VFD mode, instantaneous current phasor versus the instantaneous voltage phasor is shown.

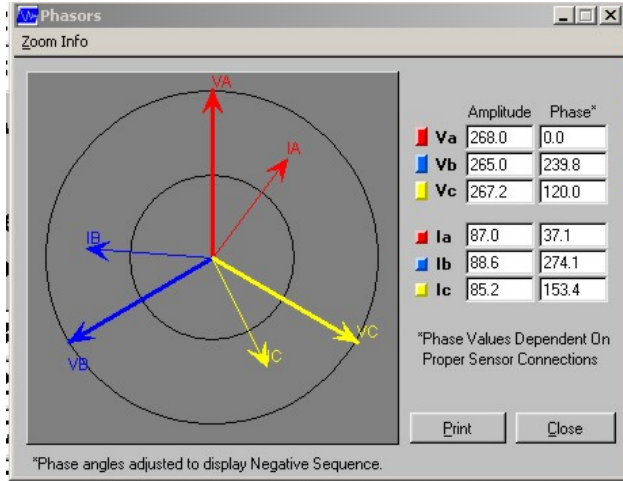

Fig 5-1: Phasors

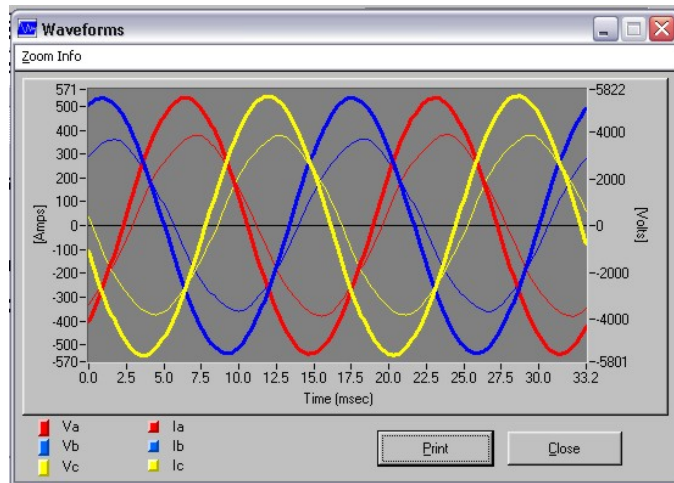

Fig 5-2: Waveforms

### Waveforms

In VFD mode, voltage and current for the phase a is shown.

### VFD details domain

In VFD mode this window displays the dynamic behavior of voltage level, torque, frequency and speed as a function of time.

As with any panel within the EXP4000 software, clicking on the zoom info panel will give the user a number of options to zoom or pan specific areas of each screens. Printing the screen is also available.

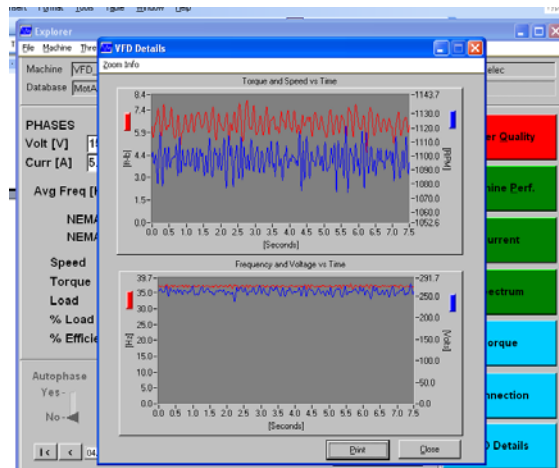

Fig 5-3: VFD details



# Continuous monitoring software

## Continuous monitoring (streaming)

The CM3000 continuous monitoring software evaluates important operating values of a machine application, including triggered acquisition and recording. It acquires 11 samples per second on 41 parameters. The graphical user interface can be rearranged during operation to suit the particular analysis needs. If recording, it stores all available

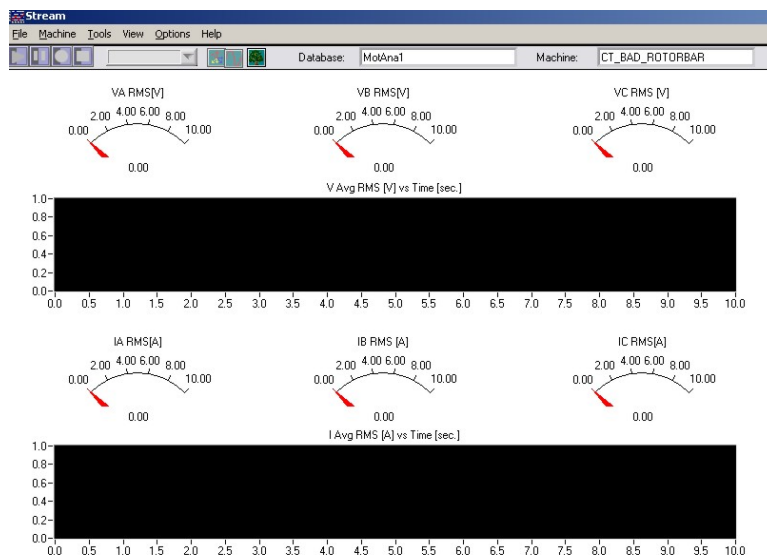

Fig 6-1: Continuous monitoring main panel

channels, not only the ones displayed. A large number of independently operating triggers can be set, and the stored data can be viewed.

## File menu

The file menu is directly linked to the main software of the EXP4000. The user can create a new database (Ctrl N), open an existing database (Ctrl O), close an existing database, or exit the program.

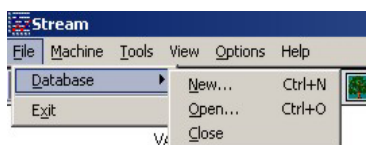

Fig 6-2: File menu

## Machine menu

The Machine menu is also interlinked to the EXP4000 main software.

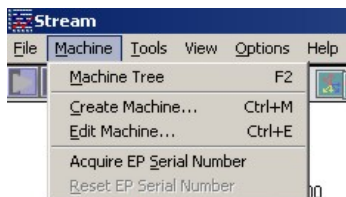

Fig 6-3: Machine menu

The user can open the machine tree (F2), create a machine (Ctrl M), edit a machine (Ctrl E), acquire EP serial number or reset an EP serial number. The gathered information will be recorded to the database.

## Tools menu

The tools menu allows the user to access the scope (Ctrl S) or view the connections. As in the other items, it is directly linked to basic software for the EXP4000.

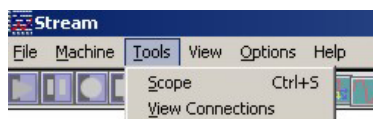

Fig 6-4 Tools menu

## View Menu

For convenience, there has been a number of preset features developed to evaluate data. These views can be used as is or the user can customize the screen through the right click menu.

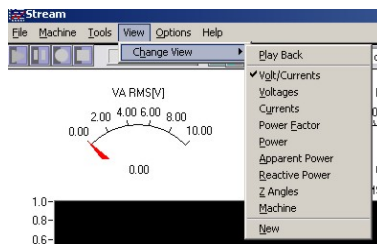

Fig 6-5: View menu



<b>View menu label</b>	<b>Definition</b>
Volts/currents	Root mean square of the currents through phases A, B, & C. This number should be between 30% and 110% of nameplate current.
Voltages	This displays the root mean square of the voltages for A, B, and C in volts.
Currents	The displays the root mean square of the current through the phases A, B and C CT's in amperes along with the average of the root mean square values of the 3 phases' currents in amperes.
Power factor	This displays the power factor phases of A, B, & C and the Average Power Factor for the phases. These values are always equal to or smaller than one, and increase with the load.
Power	This displays the single-phase real power for phase A, B, C and Total Power in kilo watts.
Apparent power	Displays single-phase complex power (9 kVA) values for phases A, B, and C in kilo volt amperes.
Reactive power	Displays single-phase reactive power for phases A, B & C and sum of the three phases in kilo volt amperes.
Z angles	Displays the angle between and current phasors of phase A, B, C and the Average Angle. This number will typically vary between 90 degrees at no load to 20 degrees at full load for induction motors.
Machine	This view displays power out, torque, speed, and percent load. The power out is the mechanical output power, the torque is the estimated torque in Nm or lb-in, the speed is the estimated speed of rotation of the shaft in RPM and finally the percent load is the output load, with respect to the motor's rating in percentage
New view	The user can create a custom view to display the items necessary to their operation.

## Options

The options menu has two items to choose from, the graph plot mode and event triggers.

### Graph Plot Mode

Within the graph plot mode choose from sweep or continuous.

When operating in sweep mode a red bar will sweep from left to right across the screen and start again at the beginning.

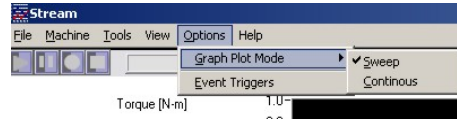

Fig 6-6: Options

In continuous mode the tool will continue to gather data and the screen will change as it reaches the far side and continues forward.

### Event triggers

Event triggers are useful to monitor data for pre-defined machine events. When the chosen condition exists, the data will be recorded for review. The software will continue to record all channels until all triggers have been recorded. At that point the software will stop and all events can be reviewed. The software can monitor any or all of the 41 active triggers listed. All channels are continuously monitored and each trigger creates a separate event, even if the time is overlapping.

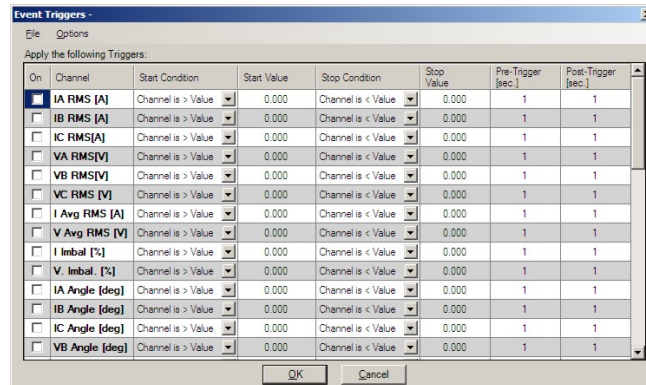

Fig 6-7: Event triggers

To set up triggers follow this procedure:

- 1) Click on options, then event triggers.
- 2) Check the box for each trigger needed.
- 3) Set the parameters needed for each trigger:
  - a. Start condition: set this to either greater than or less than the value. Click on down arrow to reveal other choices.
  - b. Start value: Type the number value appropriate for this trigger.
  - c. Stop condition: set this to either greater than or less than the value. Click on down arrow to reveal other choices. Remember this must be different from the start condition.
  - d. Stop value: Type the number value appropriate for this trigger. Remember this must be different then the start value.

- e. Pre-trigger (sec): Number of seconds prior to event the software records data.
- f. Post-trigger (sec): Number of seconds post to the event the software records data.

**Note:** If the pre and post-triggers are set to zero, the data that is recorded is just the event. If these are set to greater than zero, data will be recorded that gives information on what led up to the event and what happen after if occurred.

### General operation icons

The CM3000 software has a few built in icons that supply shortcuts to certain aspects of software operation. The icons include the initial operation of the software:

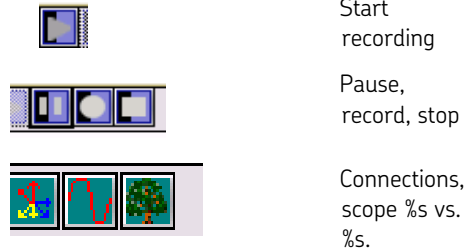

### Modifying continuous monitoring tool

The continuous monitoring software tool is user customizable. The user can set up the tool with as many of the graphs and gauges that are available, along with changing these graphs and gauges to suit the user's needs. This is accomplished through the right click menu.

This right click menu has 41 different gauges and graphs that can be added to enhance the value of information being collected.

#### Adding a new gauge or graph

- 1) With the cursor in the white space, right-click and a menu will pop up for adding a new gauge or graph.
- 2) Click on either new gauge or new graph.
- 3)

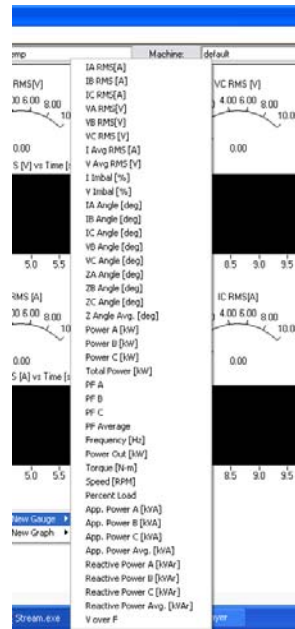

Fig 6-8: Right click menu

A list of available items will appear. Click on any of the items to create the gauge or graph.

- 4) The graph or gauge will appear and be moveable to place wherever needed on the screen.
- 5) Click to place the graph or gauge.



Fig 6-9: Scale

### ***Editing gauges and graphs***

- 1) Right click on the gauge or graph to be changed. The following screen will pop-up.
- 2) Choose Scale and the following screen will appear.

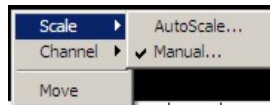

Fig 6-10: Scale - Manual

- 3) Choose either autoscale or manual. If manual is chosen, the following screen will appear. Set the values appropriately and select ok.



Fig 6-11: Set control range

- 4) If Channel is chosen, the following screen will appear. The user can click on any of the channels and the graph or gauge will automatically change to that item.

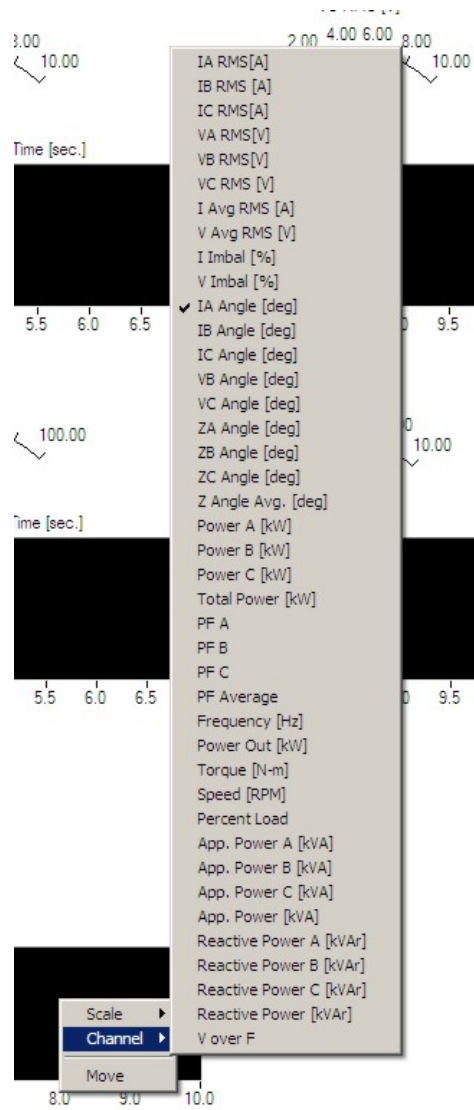

Fig 6-12: Parameters

- 5) If the move option is chosen, a hand will appear over the gauge or graph that was right click upon and this item can be moved to a different place on the screen.
- 6) To set the new location, left click.

## Channel description

Item	Description
IA RMS [A]	Root mean square of the current through the phase A-CT, in amperes. This number will typically be between 30% and 110% of nameplate current.
IB RMS [A]	Root mean square of the current through the phase B-CT, in amperes. This number will typically be between 30% and 110% of nameplate current.
IC RMS [A]	Root mean square of the current through the phase C-CT, in amperes. This number will typically be between 30% and 110% of nameplate current.
VA RMS [V]	Root mean square of the voltage A, in volts.
VB RMS [V]	Root mean square of the voltage B, in volts.
VC RMS [V]	Root mean square of the voltage C, in volts.
I Avg RMS [A]	Average of the root mean square values of the 3 phases' currents, in amperes. This number will typically be between 30% and 110% of nameplate current.
VAvg RMS [V]	Average of the three phases root mean square voltages, in volts.
I Imbal [%]	Current unbalance, in %. For machines under load, this value is typically smaller than an eighth of the % voltage unbalance
V Imbal [%]	Voltage imbalance, in %.
IA Angle [deg]	Angle between the current phasor of phase A with respect to the voltage phasor of phase A (which is locked at 0 degrees). This number is equal to <i>Za angle</i> .
IB Angle [deg]	Angle between the current phasor of phase B with respect to the voltage phase of phase A, in degrees. This number is <i>Zb angle</i> degrees away from <i>Vb angle</i> .
IC Angle [deg]	Angle between the current phasor of phase C with respect to the voltage phase of phase A, in degrees. This number is <i>Zc angle</i> degrees away from <i>Vc angle</i> .
VB Angle [deg]	Angle between the voltage phasor of phase B with respect to the voltage phasor of phase A, in degrees. This number should typically be within 3 degrees from either 120 or 240 degrees.
VC Angle [deg]	Angle between the voltage phasor of phase C with respect to the voltage phase of phase A, in degrees. This number should typically be within 3 degrees from either 120 or 240 degrees.
ZA Angle [deg]	Angle between the voltage and current phasors of phase A, in degrees. This number will typically vary between 90 degrees at no load to 20 degrees at full load for induction motors.
ZB Angle [deg]	Angle between the voltage and current phasor of phase B, in degrees. This number will typically vary between 90 degrees at no load to 20 degrees at full load for induction motors.
ZC Angle [deg]	Angle between the voltage and current phasor of phase C, in degrees. This number will typically vary between 90 degrees at no load to 20 degrees at full load for induction motors.
Z Angle Avg [deg]	Average Angle between the voltage and current phasors of their respective phases, in degrees. This number will typically vary between 90 degrees at no load to 20 degrees at full load for induction motors.
Power A [Kw]	Single phase real power for phase A, in kilo watts.
Power B [Kw]	Single phase real power for phase B, in kilo watts.
Power C [Kw]	Single phase real power for phase C, in kilo watts.
Total Power [Kw]	Total real power, in kilo watts. It is equal to $P_a + P_b = P_c$ .
Reactive Power C [kVAr]	Single phase reactive power for phase C, in kilo volt amperes.
Reactive Power Avg [kVAr]	Sum of the three phases reactive powers, in kVAr.
V over F	It displays the instantaneous ratio of voltage level divided by fundamental frequency of the voltages. For all line-driven machinery, this must be a constant. For most VFD applications, it also needs to be near a constant value.

# Vibration software overview

## Vibration Models

The vibration software allows the connection and analysis of vibration probe data on the EXP4000. The vibration application can be accessed in two ways. From an Icon on the desktop or through the EXP4000 software under tools.

## Vibration Application

### *Vibration App*

- 1) Upon entering the vibration app, the last vibration scan run is displayed on the screen.
- 2) The drop down box right of the start icon will open a drop down box that allows the user to change from Looped Acquisition to Timed Looped Acquisition. The Run 1 Now option is only available on the instrument to initiate testing. On the desktop software, this option will not be available.

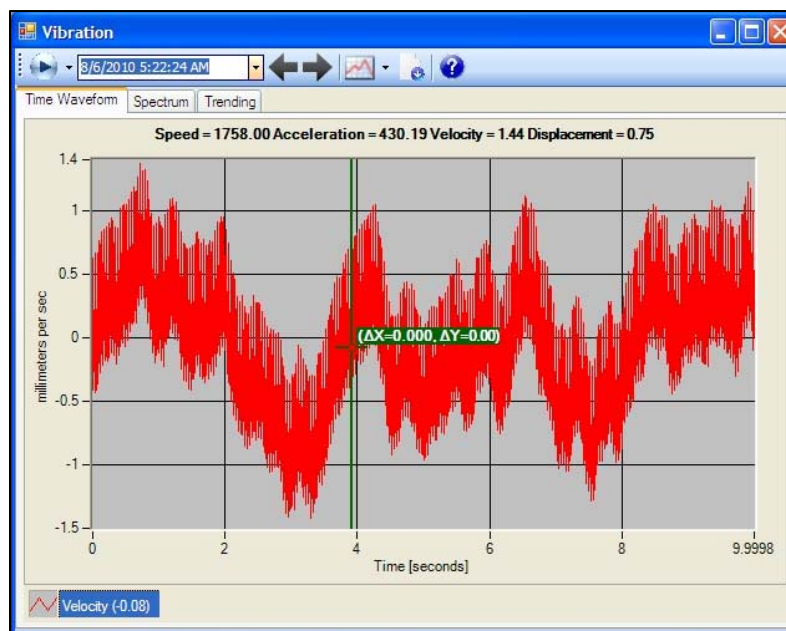

Fig 7-1: Vibration main screen

## Running a vibration scan

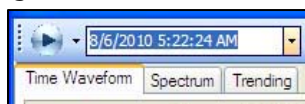

Fig 7-2: Scan start icon

- 1) Click on the start icon.
- 2) The instrument will acquire data for 10 seconds and automatically save the results and updates the screen to that scan.
- 3) If the cancel button is pressed the scan stops and will not be saved.
- 4) To view all results click on the down arrow. There are two ways to move between available tests. Either click on the down arrow on the screen to display the tests and highlight or use the right and left black arrows available to the right on the time stamp.

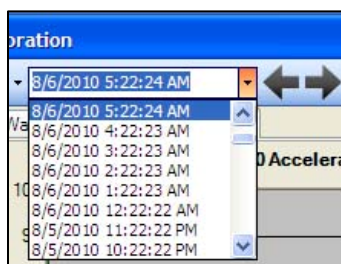

Fig 7-3: Scans records

## Running a looped acquisition scan

- 1) To run a looped acquisition, click on the drop down box next to the start button. Click looped acquisition. The looped acquisition dialog will appear.
- 2) Type in the number of tests to be conducted. The default is set to 10.
- 3) Click start. The instrument will loop through the given number of tests at 10 second intervals, saving each of the results automatically.



Fig 7-4: Looped acquisition

## Running a timed looped acquisition

- 1) To run a timed looped acquisition, click on the drop down box next to the start button. Click time looped acquisition. The dialog will appear.
- 2) Type in how many tests to be performed and at what time intervals.
- 3) Click start. The instrument will then run the required number of tests each hour and save the results.



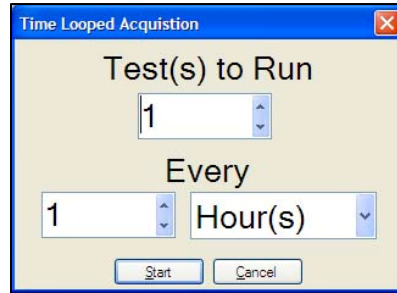

Fig 7-5: Timed looped acquisition

## Viewing results

Several options are available in view data between the time waveform, spectrum, and trending graphs. These options are also different screen between the waveform drop down button.

### View results – Time waveform

Acceleration, Velocity, Displacement or to change the graph settings click on the button with the waveform then click on the needed waveform. The screen will change to match each setting automatically.

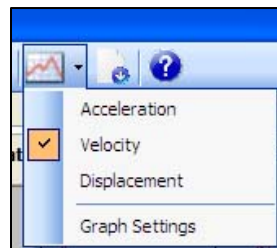

Fig 7-6: Waveform view-Time waveform

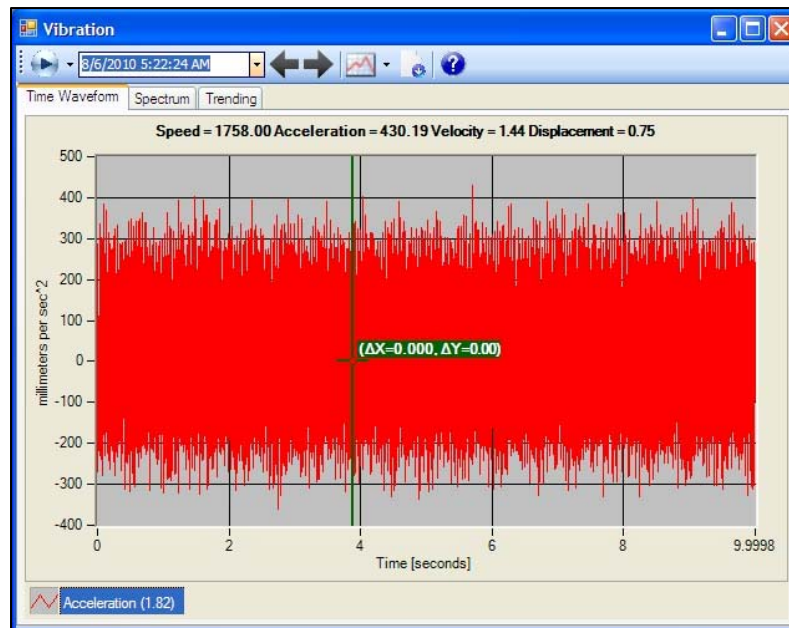

Fig 7-7: Acceleration – Time waveform

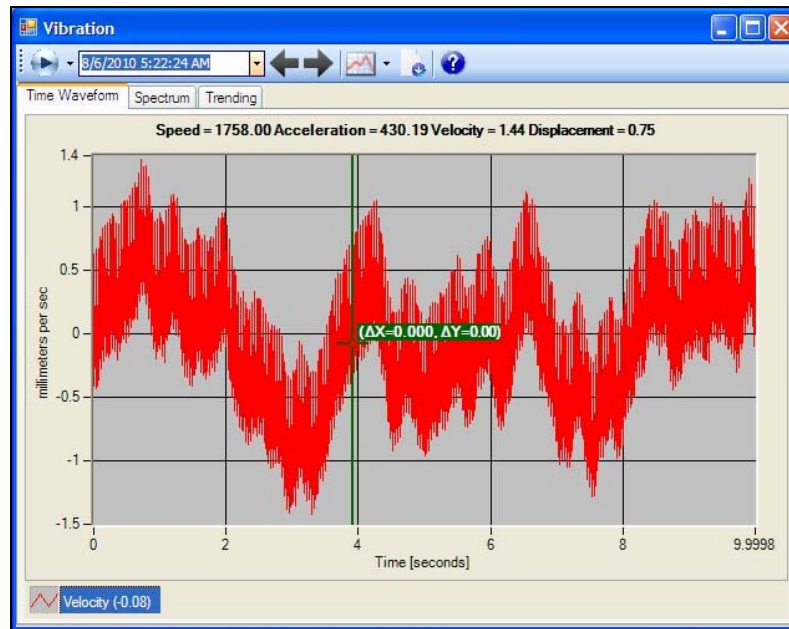

Fig 7-8: Velocity – Time waveform

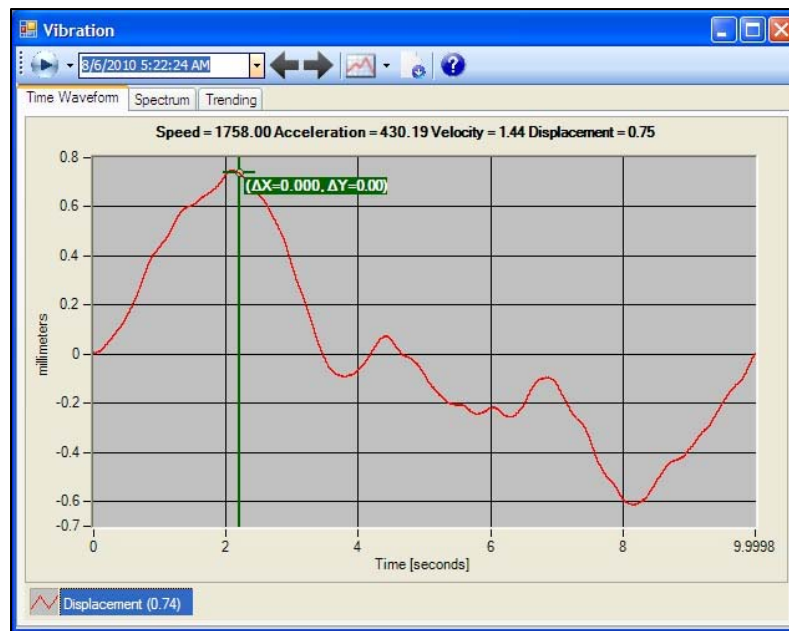

Fig 7-9: Displacement – Time waveform

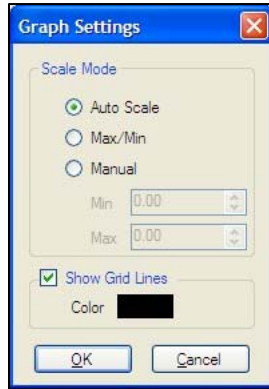

Fig 7-10: Graph settings – Time waveforms

**View Results - Spectrum**

Acceleration, Velocity, Displacement, Markers or to change the graph settings click on the button with the waveform then click on the needed waveform. The screen will change to match each setting automatically.

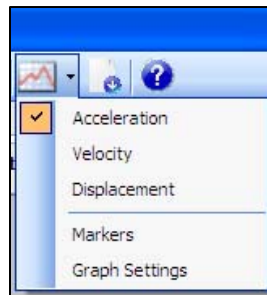

Fig 7-11: Waveform results - Spectrum

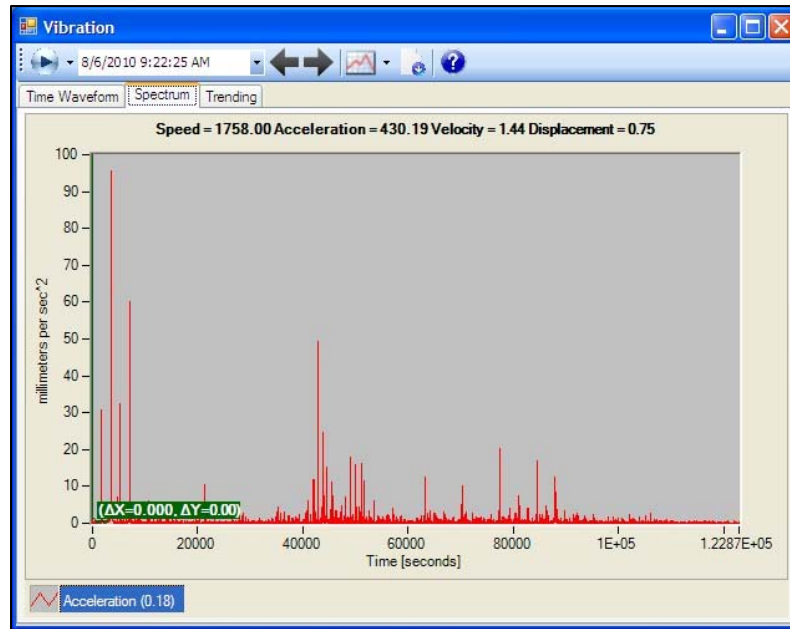

Fig 7-12: Acceleration - Spectrum

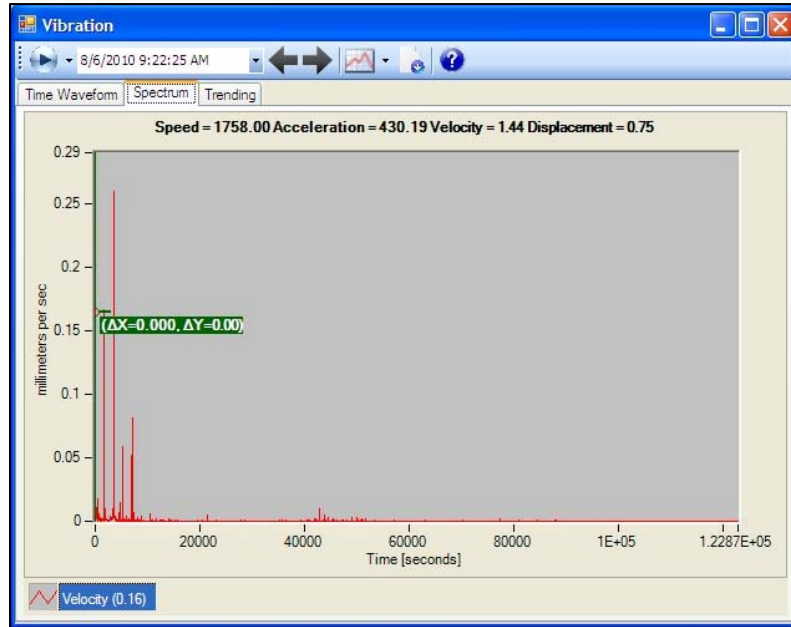

Fig 7-13: Velocity-Spectrum

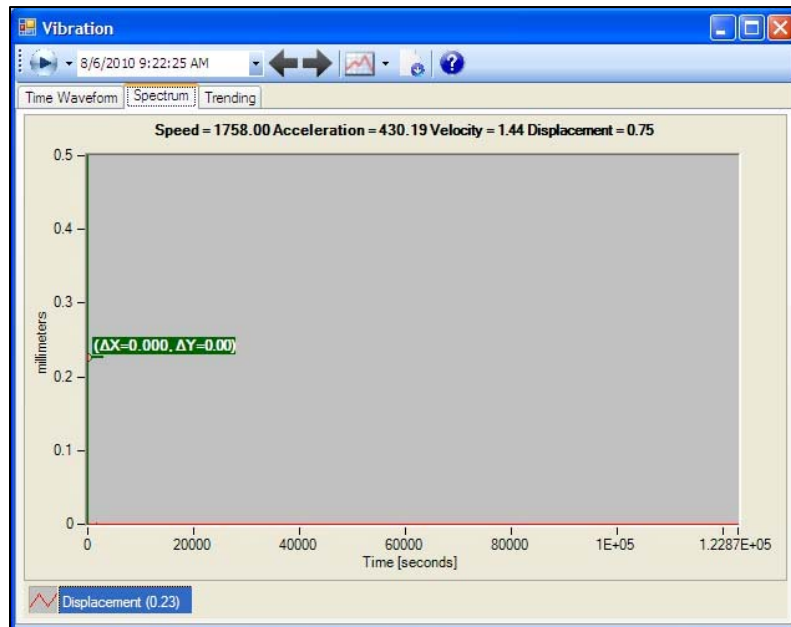

Fig 7-14: Displacement -Spectrum

Add bearings to this tree and set harmonic ranges and sideband ranges for each. Customize this view with specific color marker colors and text colors. This helps to visualize specific items when scanning for data.

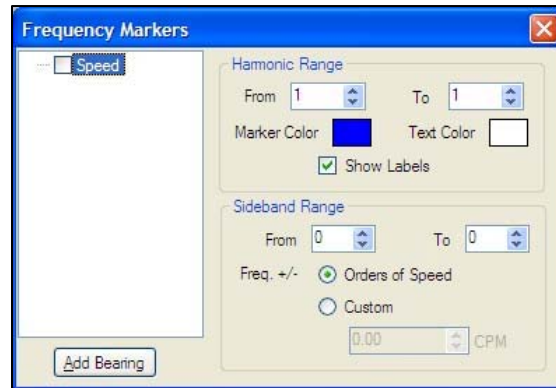

Fig 7-15: Markers - Spectrum

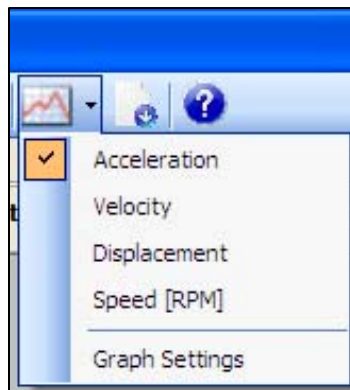

Fig 7-16: Waveform results - Trending

**View Results - Trending**

Acceleration, Velocity, Displacement, Speed or to change the graph settings click on the button with the waveform then click on the needed waveform. The screen will change to match each setting automatically.

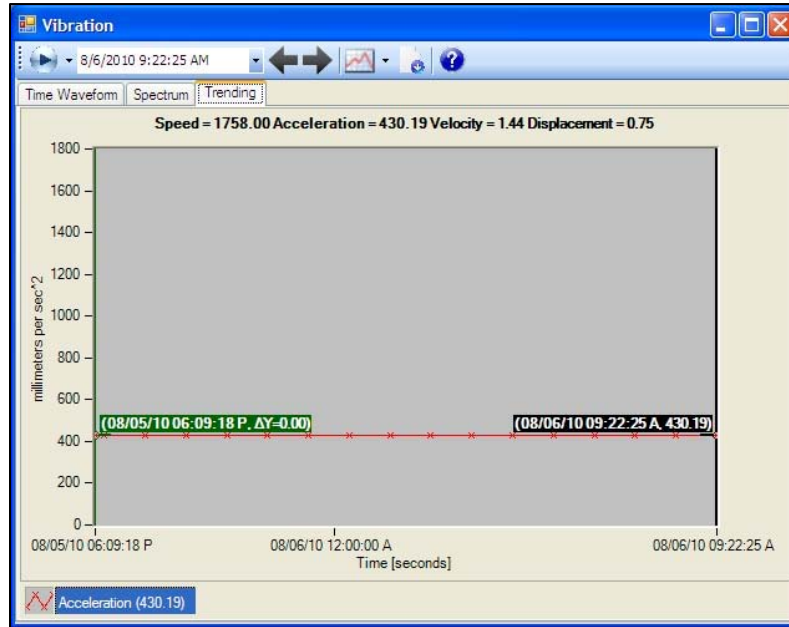

Fig 7-17: Acceleration - Trending



Fig 7-18: Velocity - Trending

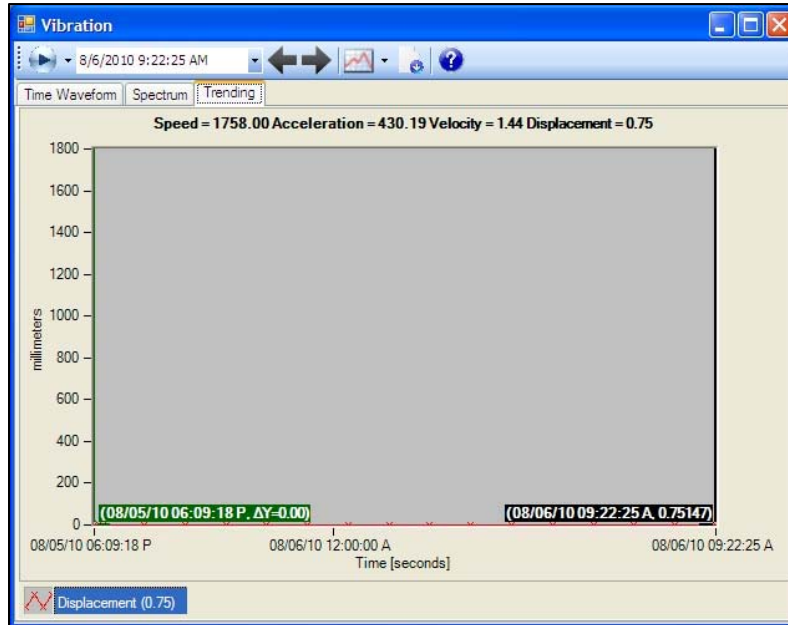

Fig 7-19: Displacement - Trending

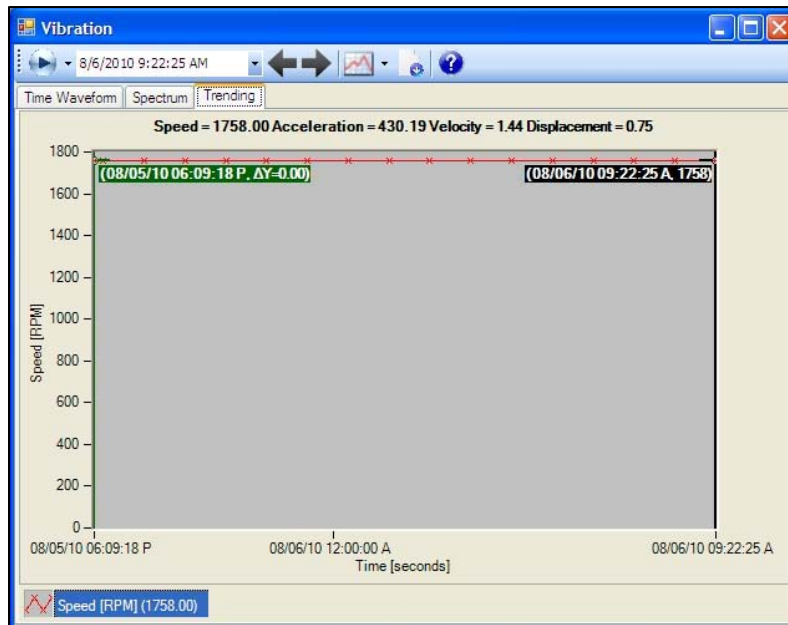

Fig 7-20: Speed - Trending

## Graph Tools

When in a graph (time waveform display, torque versus time, spectrum or trending in Use Dates mode), there are many options available to help inspect the graph.

**Zoom:** Click the mouse and drag the cursor to define the area to which to zoom. Dragging the cursor causes a dotted line to appear showing the area that will be displayed when the mouse button is released.

**Zoom X-axis only:** Click the left mouse button and drag the cursor straight parallel to the X-axis. The dotted lines showing the new display area will shift to vertical lines showing the portion of the X axis that will be zoomed to.

**Zoom Y-axis only:** Click the left mouse button and drag the cursor straight parallel to the Y-axis. The dotted lines showing the new display area will shift to horizontal lines showing the portion of the zoomed in Y-axis.

**Cancel a Zoom:** with the left mouse button still depressed, hit the escape key

**To undo a Zoom:** press the spacebar

**Undo all Zoom:** Press the Control and Spacebar keys simultaneously

## Exporting data

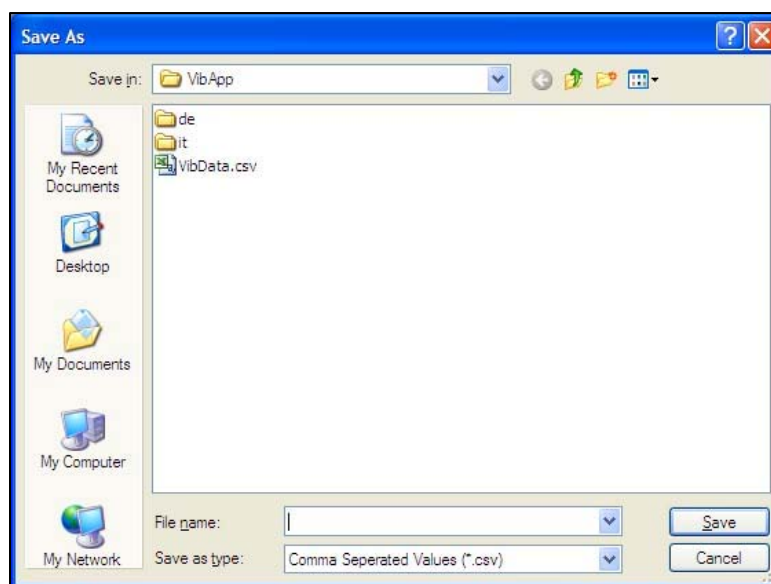

Fig 7-21: Exporting data

- 1) In order to export data to other computers, desktop software or into other software products, click on the export button and save the file as a comma delimited file for export.



# DC software overview

## DC machine Dynamic analysis software

---

### *DC summary of tests & features*

- Collect and graph field voltage
- Collect and graph field current
- Collect and graph armature voltage
- Collect and graph armature current
- Collect and graph transient data including start-up transient
- Calculate instantaneous torque and graph torque ripple and torque spectrum
- Calculate harmonics on all voltage and current data
- Calculate current spectrum
- Calculate voltage spectrum
- Cursors available to analyze torque and current spectrum data
- Data can be exported for additional analysis with programs such as Matlab or Excel

### *Types of problems identified with DC3000*

- Firing sequence and firing angle issues
- Voltage unbalance issues
- Voltage level issues
- Analyze voltage form factor
- Measure incoming power condition
- Failed SCR's or IGBT's
- Diagnose brush fire
- Diagnose brush chatter
- Diagnose drive issues
- Diagnose commutator problems
- Analyze/troubleshoot response of motor circuit
- Analyze/troubleshoot load issues
- Analyze/troubleshoot I<sup>2</sup>R issues
- Assists in setting neutral plane

## DC connections for the EXP4000 portable sensors:

### *DC sensor voltage ratings*

**NOTICE:** The maximum rating of the EXP DC voltage circuit is 500 V. 500 V is the maximum allowable voltage between any two of the four voltages and the ground clip. Under no circumstance connect the voltage sensing circuit to higher voltage levels. **This will cause severe damage to the EXP4000.**

**Terminology:**

$V_a$  – Armature Voltage       $V_f$  – Field Voltage  
 $I_a$  – Armature Current       $I_f$  – Field Current

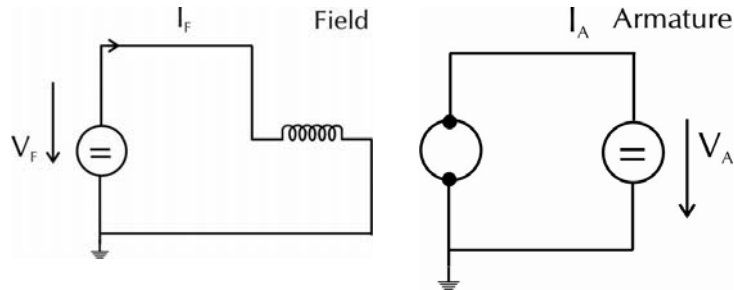

Fig 8-1: Basic diagram-separated excited DC motor

**Connection cases**

**Current sensor connections:**

I)  $I_a \leq 600A$ ,  $I_f \leq 100A$  - Standard DC portable sensors

Standard DC3000 current sensors have two ranges:

60 A/600 A -  $I_a$   
 10 A/100 A -  $I_f$

**NOTICE:** The maximum voltage rating of the EXP DC current meters are up to 600 V. Under no circumstance connect the current sensors to circuits of any higher voltage. **This will cause severe damage to the EXP4000.**

II)  $600 A \leq I_a \leq 15,000 A$ , or  $I_f > 100 A$  - Optional DC portable sensors  
 Optional DC current sensors are available, extending the current range above 600 A for the armature, and/or above 100 A for the field.

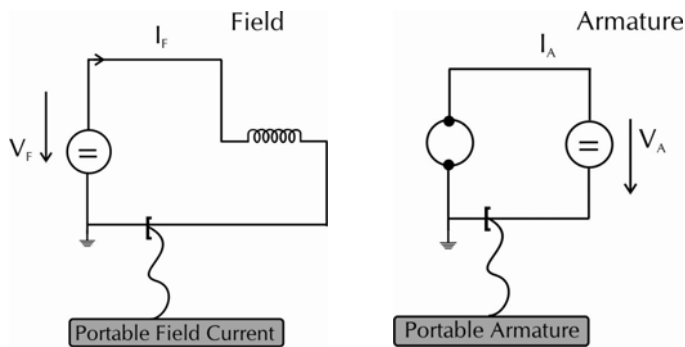

Fig 8-2 Connection diagram portable

### Voltage sensor connections:

#### $V \leq 500\text{ V}$

The EXP voltage connection is made directly across the armature voltage, or field voltage. Fig 8-3 shows the field voltage connections.

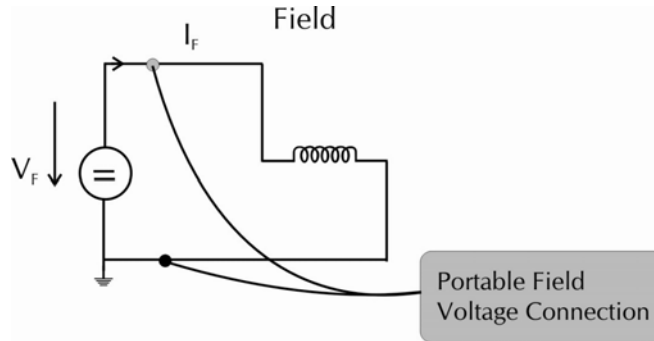

Fig 8-3: Portable field voltage connection less than or equal to 500 V

#### $V > 500\text{ V}$

If the DC motor's voltage exceeds 500 V, then a resistive bridge can be used to supply a lower, proportional voltage to the EXP4000. Fig 8-4 shows this done for the field voltage circuit.

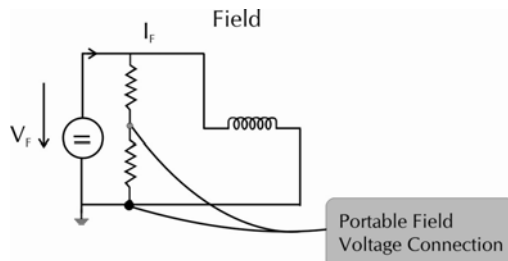

Fig 8-4: Portable field voltage connection greater than 500 V

### DC3000 software navigation and overview

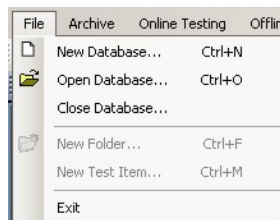

Fig 8-5 File menu

## Creating a new database

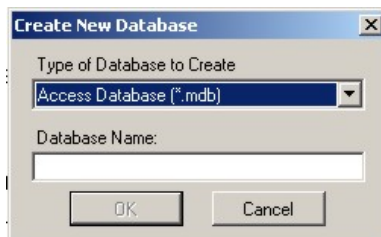

Fig 8-6: Create new database

- 1) Click File and then New Database. The following screen will appear. Type a name for the new database that is appropriate to the operation and click Ok.
- 2) This database will now appear in the tree view on the navigation pane on the screen. There are three types of database structures.
  - a. Access Database (\*.mdb)
- 3) Choose the database structure appropriate to the application.

## Opening a database

- 1) To open a database, click File and then Open Database.
- 2) The following screen will appear. Choose the appropriate database and click on Open.
- 3) This database will be active on the software.

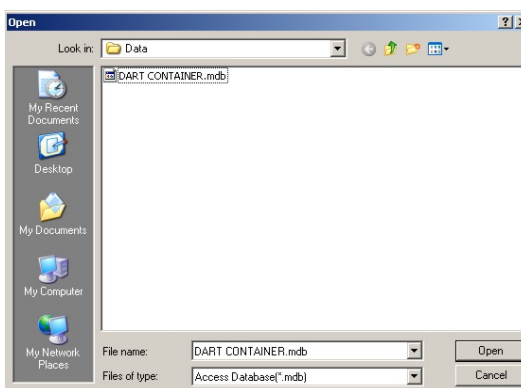

Fig 8-7: Open Database

## Close database

To close a database, click File and then Close Database. This will close the database.

## Creating a new folder

To create a New Folder, click File and then New Folder. The new folder will locate itself in the Tree View.

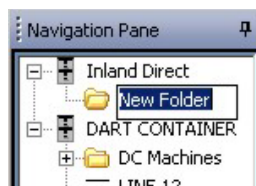

Fig 8-8: New folder

## Renaming a new folder

To rename a new folder, right-click on the new folder and then on Rename in the drop-down box and it will place a box around the new folder. Type in the appropriate name and press enter or click outside of the folder.

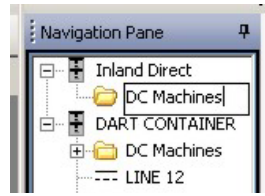

Fig 8-9: Rename folder

## Create a new test item

- 1) To create a new test item, click File and then New Test Item. A wizard will appear to help create a new machine.
- 2) Type in the appropriate machine name and click DC machine. Click Next.

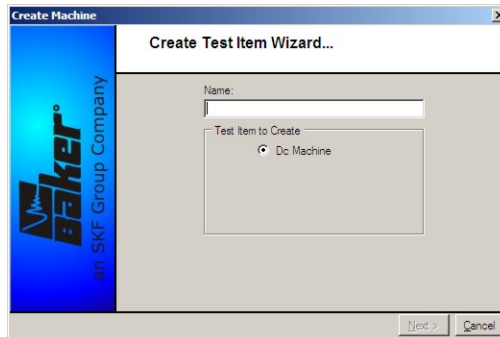

Fig 8-10: Create test item wizard

## Adding an DC machine

- 3) DC machine: There are a number of fields that have drop down boxes. The following list are required fields.

Nameplate			
<i>Please enter the information from the nameplate of the machine.</i>			
HP	0.00	kW	0.00
Base Speed [RPM]	0	Max Speed [RPM]	0
Field Volts	0	Armature Volts	0
Field Amps	0.00	Armature Amps	0.00
Number of Poles	2	Number of Commutator Bars	2
Has Interpoles	No	Frame	
Field Weakened Volts	0	Service Factor	1.00
Winding	Shunt	Enclosure	
Insulation Class	A	Max Ambient Temp. [°C]	40

Fig 8-11: Create machine – nameplate

- a) Number of poles: 2, 4 or 6
- b) Has interpoles: Yes/No
- c) Winding: Chooses between shunt, compensated shunt, or permanently excited
- d) Insulation class: A, F, B, or H.

- e) Number of commutator bars. This is display with an up/down arrow that progress in multiples of 2.
- 4) Required fields are listed in bold. Yellow fields are recommended, but can be left at default values.
- 5) After all information has been entered, click on Finish to add to machine to the list in the tree.



**Note:** A DC machine can also be added by clicking on the icon on the top navigation bar. Follow the remain procedure to complete the machine.

### Right click menu items

Within the navigation pane of the DC software there is a right click menu to help the user with a number of activities.

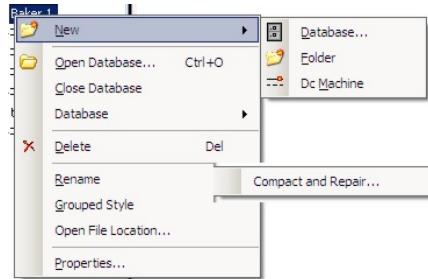

Fig 8-12: Right click menu

#### **Database or Folder View**

If located on a Database or Folder View these functions include creating a New - Database, Folder or DC Machine.

Also included are the database functions of Open or Close databases and Compact and Repair. This function keep the data in good operational order and helps the user repair the database if file corruption has occurred. This mechanism is for Access database structure only and is equivalent to defrag on a hard drive.

There are also Delete folders or machines, Rename the items, change the style of the view screen to Grouped from Standard which is used for viewing on some computer screens.

The Open File Location is operated from the database level only, and opens a window showing where the file is located on the drive. Finally, Properties for the Database and Folder level offer a brief bit of information on what the database or folder is named and when it was last modified. Properties at the machine level are much more intensive and show all information that was entered via nameplate, machine application, manufacturer, online testing and bearings. Some items within these tabs can be edited.

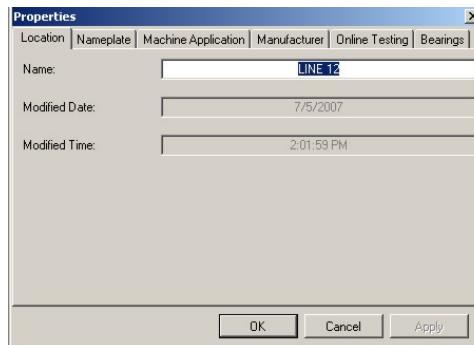

Fig 8-13: Right click menu-properties

## Online testing menu

In order to begin testing, tasks must be completed to have an understanding of what is being tested. Within the online testing menu is the ability to create, edit or delete DC test models. These models contain thresholds for both caution and warning levels.

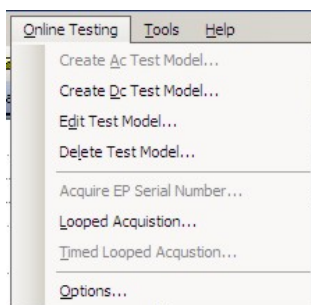

Fig 8-14: Online testing menu

### Create DC test model

- 1) Click Online Testing and then Create Dc Test Model...
- 2) Under Test Model Name type in an appropriate name for the test model. Name appropriately for the application.
- 3) Change any of the threshold levels that are appropriate by highlighting the threshold level and typing in the appropriate number. Note: Warning levels must be higher than the caution levels.

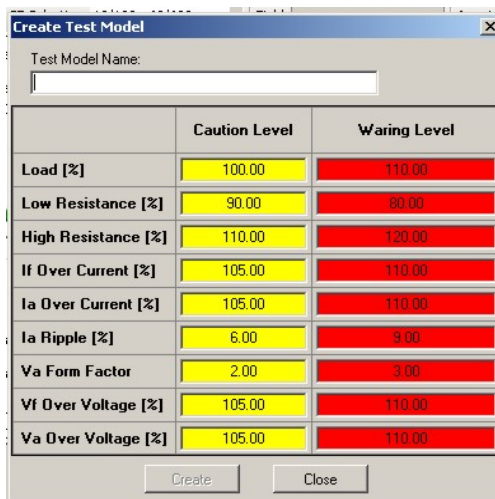

Fig 8-15: Create new test model

### Edit test model

- 1) Click Online Testing and then Edit Test Model.
- 2) Choose the Test Model to be edited from the list under Select Test Model to Edit. Change necessary items.

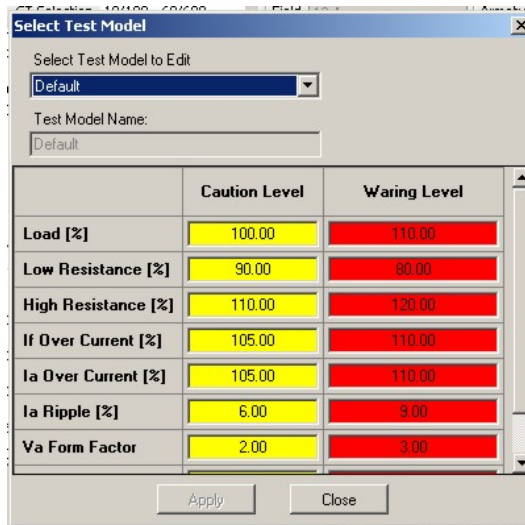

Fig 8-16: Edit Test Model

- 3) Click Apply and then Close. This saves the changes to the test model.

**Delete Test Model**

To delete a test model:

- 1) Click Online Testing and then Delete Test Model.
- 2) Choose the appropriate test model to delete from the drop down box.

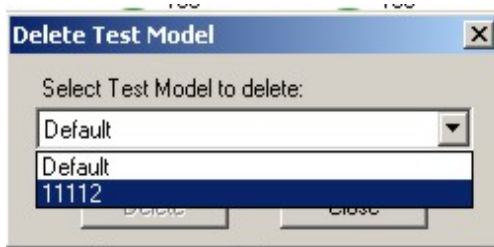

Fig 8-17: Delete Test Model

- 3) Click on Delete. A confirmation box will appear. Double check that this action is appropriate and then click on the appropriate response.

**Looped Acquisition**

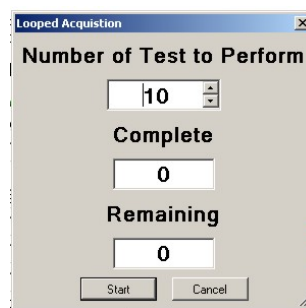

Fig 8-18: Looped Acquisition



The user can set the equipment to continually run in a looped mode for a specified number of tests.

- 1) To access the looped acquisition mode click on Online Testing and Looped Acquisition
- 2) Highlight and type in the appropriate number of tests or use the up and down arrows to reach that number.
- 3) Click start after set up is completed.

## Tools menu

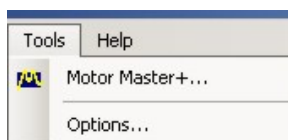

Fig 8-19: Tools Menu

There are two choices in the Tools menu. The Motor Master+ tool gives the end user a research tool for motor efficiencies and workability. It helps the user find motors of like size, capabilities, and efficiencies. It will also allow the user to research motor details to see if it is working within prescribed tolerances.

### *Options*

There are three different types of options with this menu. These options allow the user to customize several database features.

## General options:

Within the General options set the calculation path to locate the calculator. This will allow access to an online calculator. Currency can be set from here. The default is in USD.

- 1) Type in the currency that is appropriate for the region.

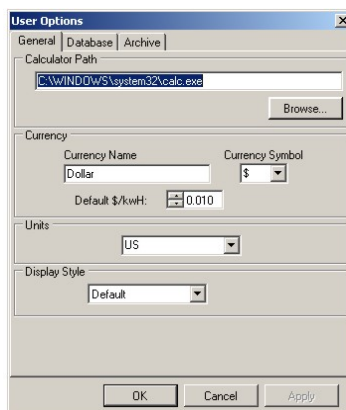

Fig 8-20 User options: General options

- 2) Select the currency symbol from the drop down box that represents the money chosen.
- 3) Set the kWh price to help calculate efficiencies and cost savings.
- 4) Select from the drop down box the equivalent unit of currency either US or Metric.
- 5) Screen colors can be changed by clicking on any of the color schemes listed.
- 6) To save changes click Apply and then OK.

## Database

The database options menu allows the user to set the location for the database files and to set what type of database is to be used as the default. The user can select from

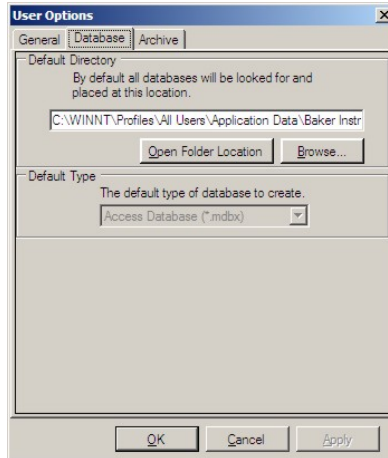

Fig 8-21 User options: Database options

Access Database (\*.mdb), Sql Express Database (\*.mdf), or Sql CE Database (\*.bic).

## Archive

This option allows the user to set the location of where archives are stored. This is an important feature to remember if ever looking for or needing to locate an archive.

Also, the Explorer creates a large amount of data points. These data points can create large databases of many mega-bytes. Within this option menu, the Max Archive Size can be set so that the data can be sent to different devices without issue. If the database is larger than the archive max size, the software will break the file size to appropriate pieces and archive all of the data.

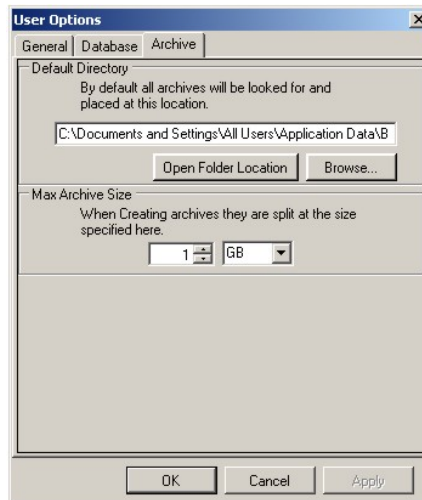

Fig 8-22: Options menu: Archive

## Software testing screen

The following description of the DC3000 software will aid in understanding how data is gathered.

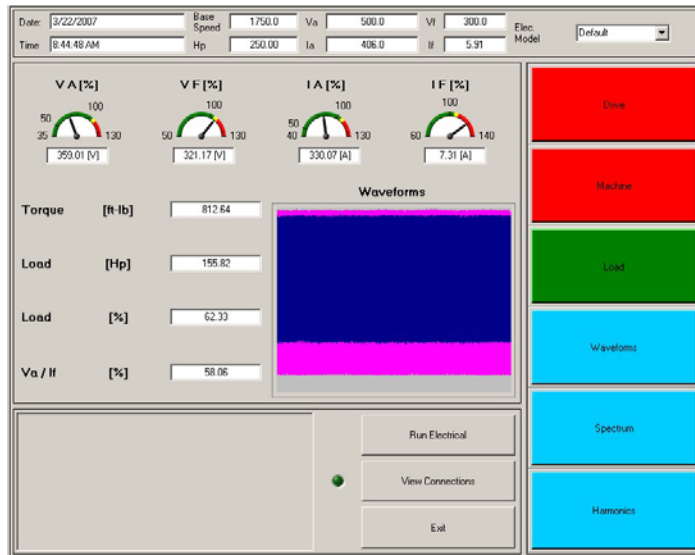

Fig 8-23: Main screen DC3000

### CT selection

On the top of the screen is a row of CT selections, one for the Field CT and one for the Armature CT. There are two selections in each. The Field CT is either 10A or 100A whereas the Armature CT is either 60A or 600A.



Fig: 8-24: CT selection

### Nameplate Information

The information listed in the top portion of the screen is from the nameplate information that was entered when the machine was created. This information is for reference for what was originally entered for the machine.



Fig: 8-25: Nameplate info

### Center Screen

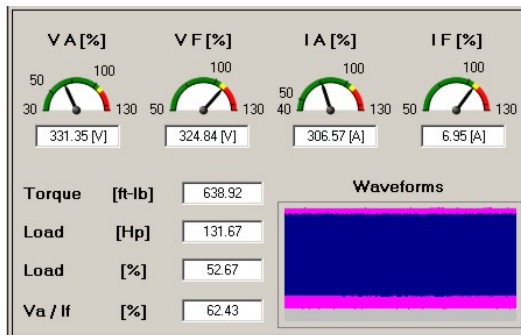

Fig 8-26: Center main screen

$$\frac{V_a}{I_f} [\%] = \text{Percentage of Synchronous Speed}$$

- VA[%] = Armature voltage percentage
- VF[%] = Field voltage percentage
- IA[%] = Armature current percentage
- IF[%] = Field current percentage
- Torque [ft-lb] = Torque in foot pounds (torque [N-m] = Torque in Newton meters)
- Load [HP] = Load in horse power (load [kW] = load in kilowatts)
- Load [%] = Percentage load
- Va/If [%] = Percentage of synchronous speed equivalent

**Parameters:**

Waveforms can be zoomed into display cycles.

- Zoom in – Shift and hold left click button then drag box around area of interest.
- Zoom out – Ctrl and right click button will return screen to original zoom level.

Practical data resulting from the Waveforms:

- Firing sequence
- Firing angles determined by amplitude of waveform
  - o Broken SCR-extreme firing angle
- Input voltage unbalance – Phases may be off; lack of symmetry in waveforms
- 3 phase (3+, 3-) SCR switching – symmetrical waveforms, unless too much ripple is present
- Typical DC drives will not have a flat waveform, due to six-pulse rectifiers or lack of ripple capacitors.

**Rule:** The field circuit does not interact with load. All load related signatures will make it into the armature but not the field.

**Bottom Main Screen**

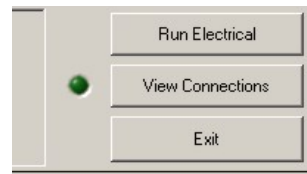

Fig 8-27: Bottom of Main Screen

**Run Electrical**

Click on Run Electrical to run programmed tests.

**View Connections**



Fig 8-28: View Connections

The view connections window gives a real-time look at input signals. Va, Vf, Ia and If are displayed in terms of average, RMS, min/max, peak-to-peak and percent of

nameplate. The graph shows waveform shape. Load and torque are plotted versus time.

**Exit**

By clicking this button, the software will exit to the desktop.

**Test Domains**

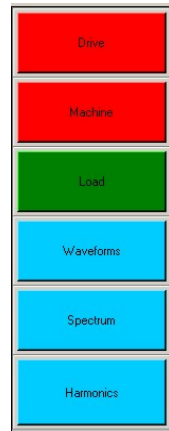

The right side of the screen has a set of test buttons known as domains. Click on each individual button to see a subset of buttons and several test results screens.

- **Drive** – Armature voltage level, field voltage level, armature voltage form factor, armature current ripple
- **Machine** – Armature current level, high field resistance, low field resistance, field current level
- **Load** – Torque ripple, load level
- **Waveforms** – Results only
- **Spectrum** – Field spectrum, armature spectrum, torque spectrum
- **Harmonics** – Results only

Fig 8-29 Domains

**Results:**

- **Green** – Machine running within tolerances. No action needed.
- **Yellow**: Machine has exceeded a caution threshold. Action should be taken to avoid future problems.
- **Red**: Machine has exceeded a warning threshold. Action needs to be taken to correct problem.
- **Blue**: No applicable thresholds.

**Drive**

The Drive domain observes the upstream power. Poor power condition will expose the motor to unnecessary stress.

- 1) Click the Drive button to view the domain tests.
- 2) Click on any test to view the results or test logs.

**Armature voltage level ( $V_a$ )**

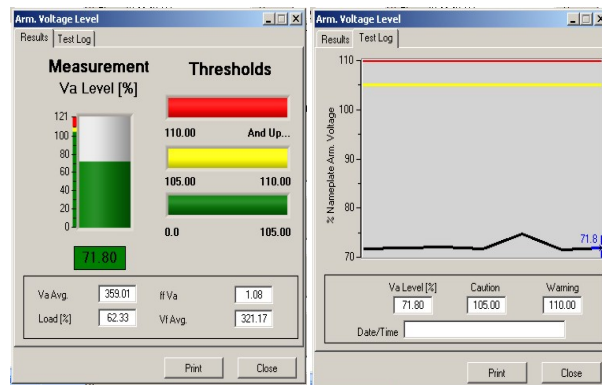

Fig 8-30: Armature voltage level

**Function of Va:** Armature voltage level is the main variable to control speed. It is always created by the drive; speed varies proportionally to Va.

- To change speed, change Va.
- To reverse direction of rotation, reverse Va.

$$Speed = \frac{k(Va - Ia \times Ra)}{If}$$

And

$$Synchronous\ Speed = \frac{Va}{If}$$

**Typical threshold:**

Nominal:  $-Va\_Nameplate < Va < Va\_Nameplate$

Warning threshold: 120% Va\_Nameplate

Caution threshold: 110% Va\_Nameplate

Standards: NEMA MG-1 Section 1-12.64

## DC machine Va troubleshooting

**Result:**  $|Va| > Va$  nameplate

**Possible problem root causes:**

- Drive settings and motor nameplate data do not coincide.
- Drive or sensor problem.
- Malfunctioning control circuit or feedback.
- Neutral plane is off.

**Possible effects:**

- Operates over rated speed motor
- Brush fire – Excessive brush sparking due to armature over voltage.
- Commutator/brush damage

**Field voltage level (Vf)**

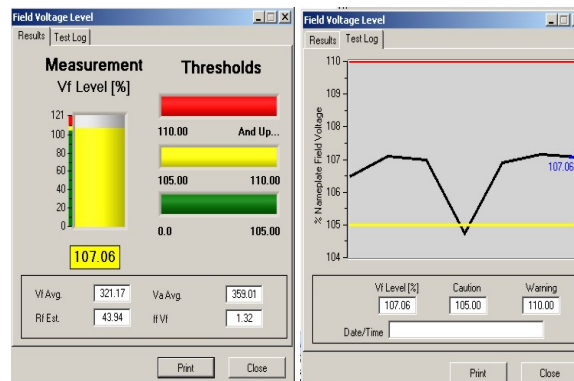

Fig 8-31: Field Voltage Level

**Function**

Connecting Vf onto the field winding causes the flow of If. This creates the magnetic field necessary for torque generation.

**Typical thresholds**

Nominal:  $|Vf\_field\_weakening| < |Vf| < |Vf\_base\_speed|$

Warning Thresholds:  $120\% |Vf\_base\_speed|$

$80\% |Vf\_field\_weakening|$

Caution Thresholds:  $110\% |Vf\_base\_speed|$

$90\% |Vf\_field\_weakening|$

Standards: NEMA MG1 Section 1-12.64

**DC machine VF troubleshooting**

**Result:**  $|Vf| > |Vf\_base\_speed|$ :

**Possible problem root cause**

Case I:  $If \leq If\_base\_speed$

- Field circuit's resistance is higher than nameplate suggests.
- Field winding is running too hot.
- Excessive contact resistance in the field circuit.
- The field circuit's lead lengths cause additional voltage drop prior to reaching field winding terminals.
- Error entering the nameplate information when creating the motor.

**Possible Effects:**

- Contact resistances tend to increase over time. Following this trend, the worsening contact resistance will lead to over speed trip, or over speed damage to the motor.
- The field's resistance varies too much from the drive's motor model, which may introduce stability problems to speed or torque control.
- On inexpensive motors with no speed control, the motor can overspeed, possibly causing damage.
- Field lead lengths cause additional voltage drop prior to reaching field winding terminals.
- Many drives have motor models used to offer higher quality speed/torque controls. The field's resistance varying too much from the drive's motor model may introduce stability problems to speed or torque control.

**Possible problem root cause**

Case II:  $If > If\_base$

- Drive setup problem.
- Drive or sensor malfunction.
- Short in field.

**Possible Effects:**

- Many drives have motor models used to offer higher quality speed/torque controls. The field's resistance varying too much from the drive's motor model may introduce stability problems to speed or torque control.

Results:  $|V_f| < |V_{f\_field\_weakening}|$ :

**Possible problem root cause**

Case I:  $I_f < I_{f\_field\_weakening}$

- Drive setup problem
- Drive or sensor malfunction

**Possible Effects:**

- Over speed trip.
- Over speed damage.
- Series poles connected in series have been removed from the circuit.

**Possible problem root cause**

Case II:  $I_f \geq I_{f\_field\_weakening}$

- Field circuit's resistance is lower than nameplate suggests.
- Field winding's temperature is below standard ambient (40° C) or motor may not have warmed up yet.
- Series elements of the field winding are not part of the circuit (turn-turn faults)
- Nameplate vs. Motor issue:
  - Error entering the nameplate when creating the motor.
  - Motor's nameplate doesn't properly represent the field circuit.
  - If the field circuit's resistance is lower than the nameplate suggests.

**Possible Effects:**

If the field winding has a turn-turn fault, and if the field voltage has noticeable harmonic components, the shorted turns are being overheated. The field's ground-wall insulation will fail prematurely. The amount of overheating due to the harmonic current content depends upon the amount of  $V_{f\_ripple}/V_f$ .

If the ambient temperature is below standard ambient (40° C), and the motor has not operated for a long enough time, then the field winding is still in the process of heating up. If the drive does not change the  $V_f$ , then  $I_f$  will keep falling until the field winding reaches a steady state temperature.

Many drives have motor models used to offer higher quality speed/torque controls. The field's resistance varying too much from the drive's motor model may introduce stability problems to speed or torque control.

- If the motor's nameplate doesn't properly represent the field circuit:

The field's resistance varies too much from the drive's motor model, which may introduce stability problems to speed or torque control.



### Armature Voltage Form Factor

Function: Form Factor is defined as:

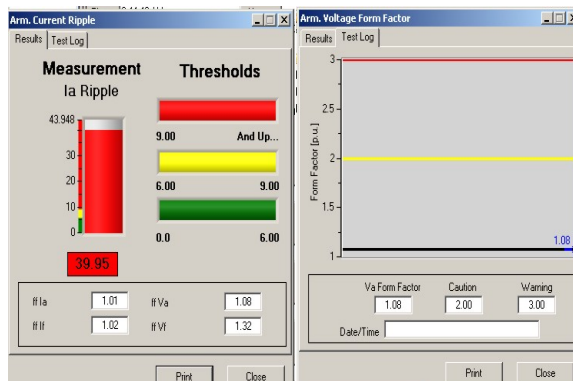

Fig 8-32: Armature Voltage Form Factor

$$Va \text{ Form Factor} = \frac{Va_{RMS}}{Va_{Average}}$$

This is a representation of how much Va differs from a pure DC signal. The closer Va form factor is to 1.0, (the theoretical minimum), the cleaner the signal. Va form factor greater than 1.0 indicates AC current components in the armature and could mean more losses.

#### Typical thresholds

The following boundaries apply to DC motors operating from a rectified AC supply.

- Warning thresholds:      120% Va\_Rated      80% Va\_Rated
  - Caution thresholds:      110% Va\_Rated      90% Va\_Rated
- Standard: NEMA MG-1 Section 1-12.64

#### DC Machine Va form fact troubleshooting

**Result: Va form factor is too high:**

##### Possible problem root cause

- Excessive voltage unbalance feeding the drive.
- Unsymmetrical firing of the drive's armature circuit switches.
- Drive's number of pulses too low.

##### Possible Effects:

The drive's supply introduces excessive variations in the motor's armature current. This creates excessive torque ripple for applications defined as essentially torque ripple free. Some applications, for example extruders, do only function properly if the supplied torque is sufficiently constant. An excessive Va form factor may cause excessive Ia ripple, resulting in additional commutator sparking.

### Armature Current Ripple

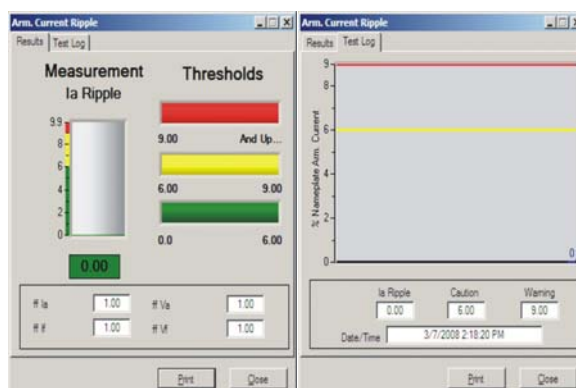

Fig 8-33: Armature current ripple

**Function:** This is current that produces no torque, yet produces heat. Primarily,  $I_a$  ripple is the response of the circuit to the armature voltage AC components. The inductance of the motor (and any additional users supplied inductance) can smooth out the armature current ripple at least to some extent. A reduction in the RMS armature current ripple reduces the heating of the motor, while a reduction in peak-to-peak armature current ripple improves the commutating ability of the motor.

$$I_a \text{ Ripple Factor} = \frac{(I_{a_{\max}} - I_{a_{\min}})}{I_{a_{NP}}}$$

#### Typical thresholds

Warning threshold:  $2.5 < I_a$  ripple factor

Caution threshold:  $6.0 < I_a$  ripple factor  $< 2.5$

Standards: NEMA MG-1 Section 1-14.61

#### DC machine $I_a$ ripple troubleshooting

**Result: Armature current ripple is too high:**

##### Possible Root Cause

- $V_a$  Form is too High:
- Drive Malfunction.
- Timing of SCR's is Wrong
- High AC voltage unbalance
- Armature circuit's inductance too small.

##### Possible Effect

- The drive's supply introduces excessive variations in the motor's armature current. This creates excessive torque ripple for applications defined as essentially torque ripple free. Some applications, for example extruders, do only function properly if the supplied torque is sufficiently constant.
- AC current components contribute more to heating than to torque generation – aging the armatures prematurely. Additionally, AC armature current components diminish the commutation capacity.

## Machine

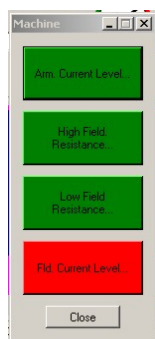

The Machine domain displays the issues directly related to the motor's health. A machine can be a motor or a generator.

- 1) Click on the machine domain button.
- 2) Click on any of the machine domain tests to view the test results or logs available.

Fig 8-34: Machine domain

### Armature current level

**Function:** Ia level represents the current flowing through the armature winding.

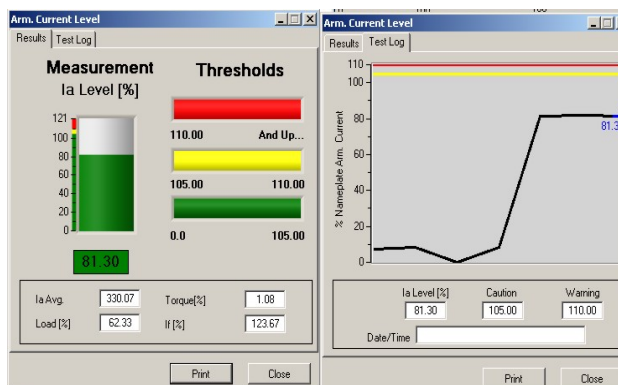

Fig 3-35: Armature current level

### Typical thresholds

Warning threshold: 120% rated < Ia

Caution threshold: 110% rated < Ia < 120% rated

### DC machine Ia troubleshooting

#### Possible problem root cause

- Va level is too high.
- Excessive torque is demanded by the load.
- Armature may have stalled.
- No current in the field.

#### Possible Effects

- Brush fire.
- Commutator/brush damage.

**High Field Resistance**

**Function:** Comparison of calculated field resistance to field resistance at rated conditions.

$$R_f = \frac{V_f}{I_f}$$

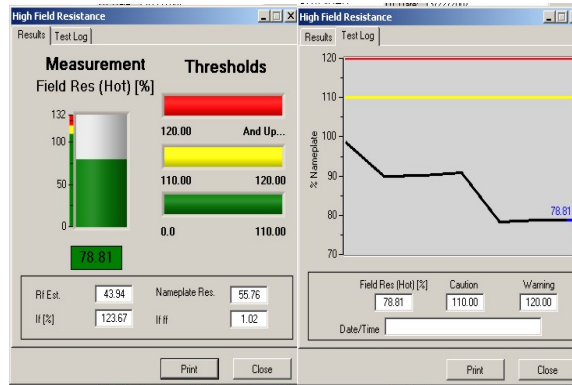

Fig 8-36: High field resistance

**Typical thresholds**

$$R_{fHot} = \frac{V_{frated}}{I_{frated}}$$

Warning thresholds:  $120\% R_{fHot} < R_f$

Caution thresholds:  $110\% R_{fHot}$ ,  $R_f$ ,  $120\% R_{fHot}$

**Result:** Field resistance is too high

**DC machine Field Resistance troubleshooting****Possible problem root cause:**

- High temperature
- High contact resistance
- Small copper

**Possible cause**

- Shortened insulation life

**Low field resistance**

**Function:** The calculated field resistance is compared to field resistance at rated conditions extrapolated to the lower boundary of the insulation class. See high field resistance.

$$R_f = \frac{V_f}{I_f}$$



Fig 8-37: Low field resistance

### Typical thresholds

$$R_{f(cold)} = R_{f(hot)} \times \Delta T$$

Where:

$\Delta T$  = per unit resistive increase for copper going from ambient temperature up to hottest allowable temperature for that insulation class.

Warning threshold:  $80\% R_{fcold} > R_f$

Caution threshold:  $90\% R_{fcold} > 80\% R_{fcold}$

### DC machine Low Field Resistance troubleshooting

#### Result:

- Turn-to-turn short
- Field winding is below NEMA ambient temperature (40°C)

#### Possible effects:

- Shortened motor life.
- Motor was very recently started.
- Ambient temperature is very much below 40°C.

#### Field current level

**Function:** If level corresponds to the current flowing through the field winding. **Note:** It is critical that the field current never falls too low or moves through the zero point, otherwise, the motor could over speed or stall.

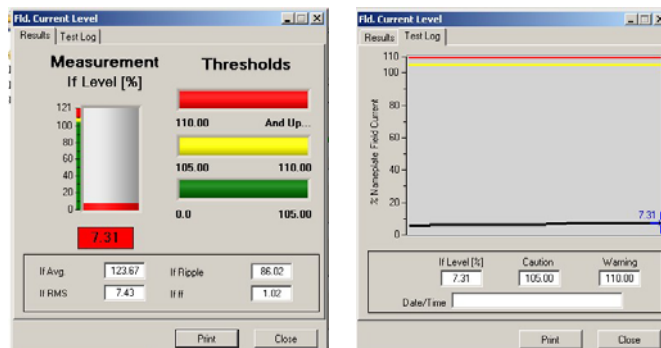

Fig 3-38: Field current level

**Typical thresholds**

Warning threshold: 120% rated < I<sub>f</sub>

Caution threshold: 100% rated < I<sub>f</sub><120% rated

**DC machine I<sub>f</sub> troubleshooting**

**Result:**

Field current level is too high.

**Possible problem root cause:**

- V<sub>f</sub> too high.
- Field circuit resistance too low or cold field windings.
- Short in field windings.

**Possible effects:**

- Too many I<sup>2</sup>R losses.

**Result:**

Field current level is too low.

**Possible problem root cause**

- High temperature.
- High contact resistance.
- Long leads of small diameter copper.

**Possible effects**

- Over speed.
- Stalling.

**Load**

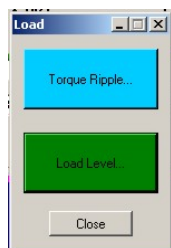

The load domain uses the motor as a sensor to look at the driven load. To fully describe the steady state behavior two components are supplied

- **Torque ripple:** Imaged data short-term behavior as well as load signature.
- **Load level history:** long-term behavior is made viewable.

Fig 8-39: Load domain

- 1) Click on the Load domain to view tests.
- 2) Click one either of the domain tests buttons to view the test results or logs available.

**Torque ripple**

Torque ripple is defined as the division of maximal torque divided by average torque during the acquisition period.

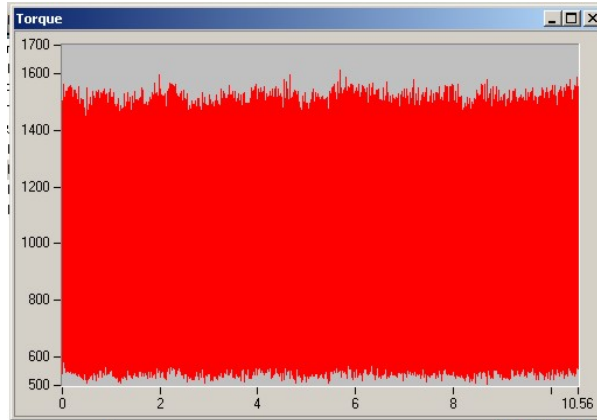

Fig 8-40: Torque ripple

**Function:**

Torque ripple is a measure of how small the torque band is that surrounds a steady state average torque.

An important feature of the graph is the overall signature of the instantaneous torque (torque versus time plot). This signature is the result of the load requirements of the drive.

$$T = k \times I_a \times I_f$$

**Boundaries:** N/A – blue results

**Results: Torque ripple is too high**

A torque ripple in a ripple-free application indicates a problem.

**Possible problem root cause**

- Load problem
- Drive problem

**Load level**

The motor is required to deliver the load level requested by the load. If there is a change in the load level, the root cause of that change lies in the driven load, not in the motor's capabilities.

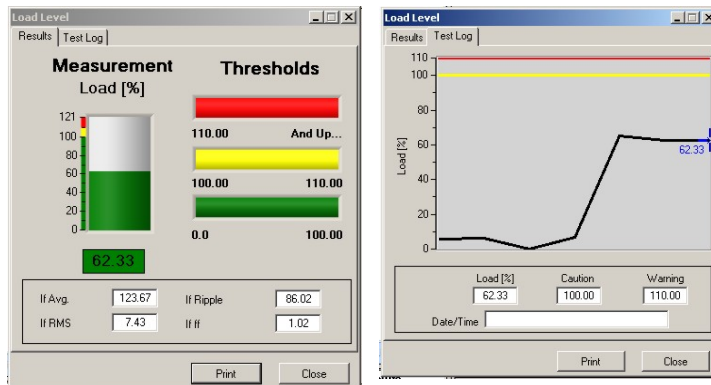

Fig 8-41: Load level

**Function:**

Load level displays the test history of the load Dynamic monitoring identifies deterioration, which in most cases is gradual making trending important. A gradual increase of load can be a sign of additional friction in the driven belt system. A decrease can be traced back to a gradual blockage of the inlet of a fan or a pump. Changing loads can only be diagnosed with detailed knowledge of the operating process. Expertise in the particular driven load is necessary to determine whether the measured change is meaningful for predictive maintenance.

**Typical thresholds**

Warning threshold:  $120\% < \text{load}$

Caution threshold:  $110\% < \text{load} < 120\%$

**Possible problem root cause**

In case load level is too high:

- Load level problems are always caused by the load.

**Possible effects:**

- Overheating

**Waveforms**

Waveform shape can be indicative of drive or motor problems. For example, if every sixth peak of the  $V_f$  or  $V_a$  waveform is smaller than the rest, it is possible that one SCR on a six-pulse rectifier is not firing properly. Typically, there are no ripple capacitors in a DC drive, so these waveforms typically are not flat. In addition, an entire missing tooth in the waveform could indicate a broken SCR. Voltage unbalance should also be visible. Because there is more inductance in the field than in the armature,  $I_f$  should normally be relatively small (high resistance) with less ripple than  $I_a$ .

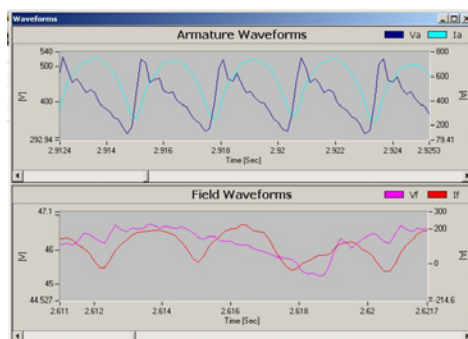

Fig 8-42: Waveforms

**Spectrum**

Spectra are useful for analyzing the frequency content of time-domain signals.  $V_a$ ,  $I_a$ ,  $I_f$ ,  $V_f$  and torque are transformed to the frequency domain with the DFLL (Digital Frequency Locked Loop) and/or the FFT (Fast Fourier Transform).

- 1) Click on the spectrum domain button to view the spectrum tests.
- 2) Click on any of the test buttons to view the graphical spectrum test results.

**Field Spectrum**

$V_f$  and  $I_f$  should have similar spectra at lower frequencies. As frequency increases, impedance also increases (the impedance is mostly inductive), resulting in  $I_f$  spectrum beginning to decrease in amplitude at higher frequencies.



The field circuit does not interact with the load, so any issues found in the field spectra have to be the result of the voltage sources, the resistance of the field or the inductance of the field.

A field circuit powered by rectified three-phase AC should display harmonics at the following locations: DC, 6<sup>th</sup>, 12<sup>th</sup>, 18<sup>th</sup>, etc. There should be no harmonics at multiples of the second harmonic: 2<sup>nd</sup>, 4<sup>th</sup>, 8<sup>th</sup>, etc. The presence of a second harmonic multiple could be due to voltage unbalance at the input of the DC drive.

For low ripple applications having excessive  $I_f$  ripple, the inductance of the field circuit could be too low. This can be corrected by adding additional inductance externally to the drive and/or motor field circuits.

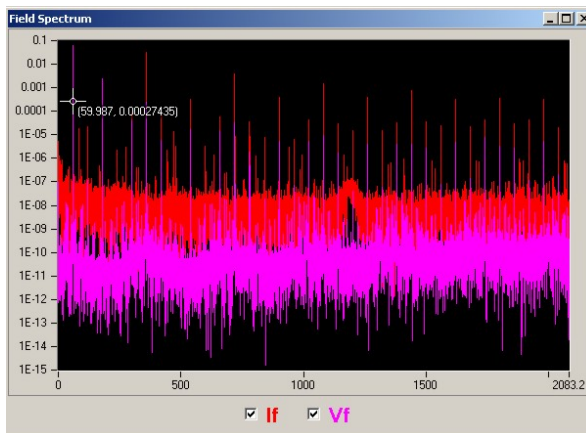

Fig 8-43: Field spectra

**Armature spectrum**

As with field,  $V_a$  and  $I_a$  should have similar spectra at lower frequencies. However, as frequency increases, impedance also increases (the impedance is mostly inductive). As a result, the  $I_a$  spectrum should decrease in amplitude at higher frequencies. If this is not the case, it is due to the machine.

The armature spectra is useful in identifying the following problems.

- Raised bar
- Raised Mica
- Chattering
- Neutral plane problems.

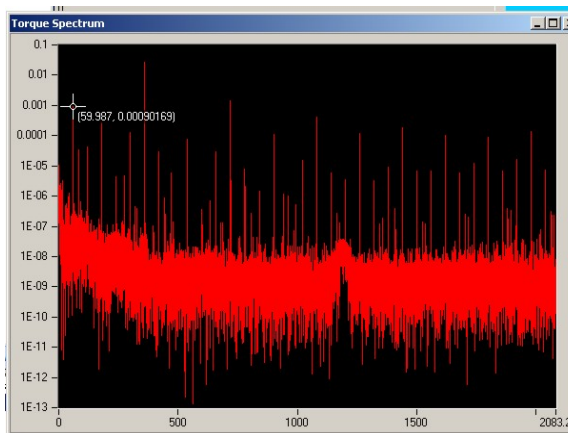

Fig 8-44: Armature spectra

### Torque spectrum

The torque spectrum is composed of both electrical and mechanical components. The electrical component can be reduced by addressing issues pertaining to **Va form factor** and **armature current ripple**, such as voltage unbalance, unsymmetrical firing of SCR's and insufficient drive pulses. Some applications such as extruders, require very little torque ripple. In these applications, it is critical that the ripple be addressed. Once the electrical components of the torque spectrum have been isolated, whatever is left is a mechanical signature.

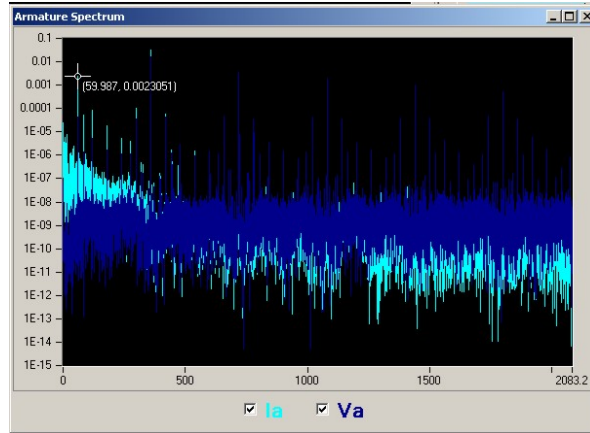

Fig 8-45: Torque spectra

### Harmonics

Harmonics provide an indication of how much alternating current is feeding the DC current motor. When a DC current motor is operated from a rectified alternating current source, rather than from a low ripple source such as a battery, the performance could be affected, possibly resulting in increased temperature and decreased commutation and efficiency.

A DC motor operated from rectified three-phase AC should display harmonics at the following locations: DC, 6<sup>th</sup>, 12<sup>th</sup>, 18<sup>th</sup>, etc.

- 1) Click on the harmonics domain button to view the harmonics involved with the machine under test.
- 2) To view the harmonics in different formats, click on the tabs on the top of the screen.
- 3) Click on the check box to view all four channels or as few as needed for each

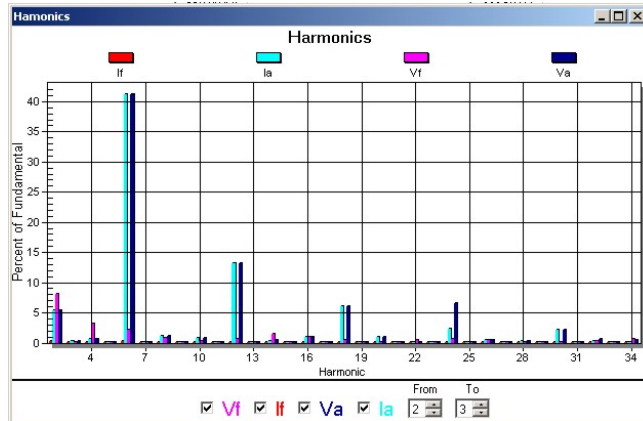

Fig 8-46: Harmonics

- channel:  $I_f$ ,  $I_a$ ,  $V_f$ ,  $V_a$ .
- 4) Click on export to view the available data formats. This allows data to be displayed in several formats, clipped to the clipboard, exported to a file for email, or sent directly to a printer. Size definitions are also available. The unit of measure is pixels.

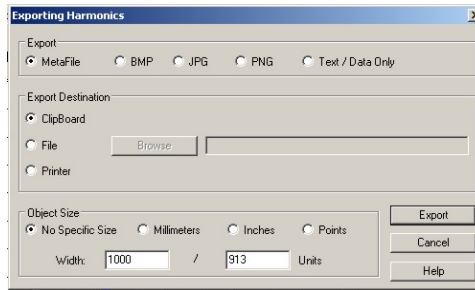

Fig 8-47: Export harmonics

### Result

The presence of any other harmonic, particularly the 2<sup>nd</sup>, indicates a lack of symmetry (except for the case of a single-phase rectifier). Unusually large harmonics represent:

- On  $V_a$  can indicate an unbalance on the rectified supply.
- A blown SCR.
- On  $I_a$  can indicate a high contact resistance.

### Reports

To generate a report, select the test records desired. To select multiple test records simply use the Ctrl or Shift Keys as in any Windows format. Right click and select add to report. The report will be created and a popup box will appear to save the report in a .rtf (rich text format) that can be opened in a number of different software packages.

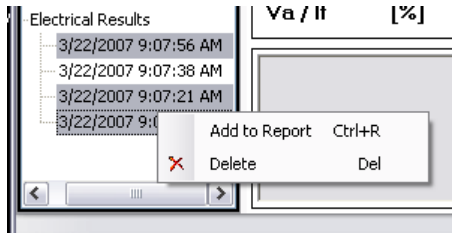

Fig 8-48: Right click menu - reports

<b>Explorer DC Electrical Result</b>	
<b>Machine Name:</b>	LINE 2
<b>Location</b>	DART CONTAINER\LINE 2
<b>Test Date/Time</b>	3/22/2007 9:07:56 AM
<b>Report Date</b>	8/15/2007 7:08:34 PM
<b>Explorer SN#</b>	\$(TESTERSN)\$

<b>Nameplate Data:</b>			
<b>Hp</b>	250.00	<b>kW</b>	186.50
<b>Base Speed [RPM]</b>	1750.00	<b>Max Speed [RPM]</b>	1750.00
<b>Field Volts</b>	300.00	<b>Armature Volts</b>	500.00
<b>Field Amps</b>	6.55	<b>Armature Amps</b>	402.00
<b>Winding</b>	Shunt	<b>Insulation Class</b>	A

<b>Measurements</b>		
	<b>Field</b>	<b>Armature</b>
<b>Average Voltage</b>	324.84	331.36
<b>Max Voltage</b>	693.46	658.42
<b>Min Voltage</b>	-13.95	71.27
<b>% Rated Voltage</b>	108.28	66.27
<b>Average Current</b>	6.95	306.57
<b>Max Current</b>	10.23	384.23
<b>Min Current</b>	3.27	191.18
<b>% Rated Current</b>	106.15	66.27

<b>Test</b>	<b>Value</b>	<b>Status</b>	<b>Caution Level</b>	<b>Fail Level</b>
<b>Field Voltage Level</b>	324.84	Caution	31500.00	33000.00
<b>Arm. Voltage Level</b>	331.36	Pass	52500.00	55000.00
<b>Arm. Voltage FF</b>	1.33	Pass	2.00	3.00
<b>Arm. Current Ripple</b>	48.02	Fail	6.00	9.00
<b>Arm. Current Level</b>	306.57	Pass	42210.00	44220.00
<b>High Field Resistance</b>	146.01	Fail	110.00	120.00
<b>Low Field Resistance</b>	233.61	Pass	90.00	80.00
<b>Field Current Level</b>	6.95	Caution	687.75	720.50
<b>Load Level</b>	0.00	Pass	100.00	110.00

**Notes:**

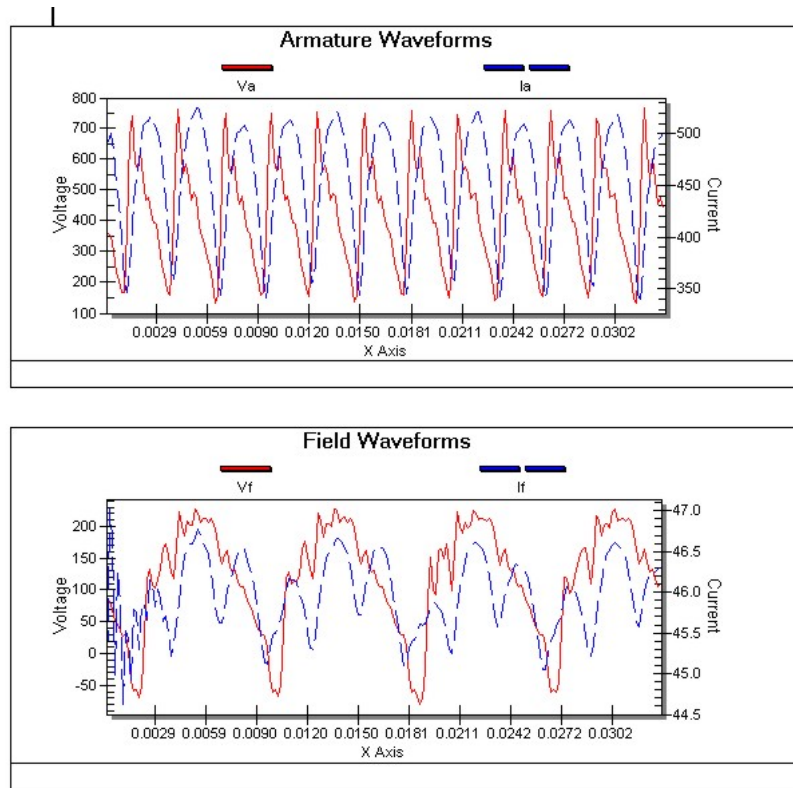

Fig 8-49: Sample report



# Physical connection of the the EXP4000/Connection setup wizard

## Connecting the EXP4000

---

### Important safety information

#### General Safety Precautions

**Note:** The general safety information presented here is for both operating and service personnel. Specific “warnings” and “cautions” will be found throughout this manual where they apply.

**Note:** If the equipment is used in any manner not specified by Baker Instrument Company, an SKF Group Company, the safety protection provided by the equipment may be impaired.

#### Safety term definition

**DANGER:** Indicates a hazardous situation, which, if not avoided, will result in death or serious injury.

**WARNING:** Indicates a hazardous situation, which, if not avoided, could result in death or serious injury.

**CAUTION:** Indicates a hazardous situation, which, if not avoided, could result in minor or moderate injury.

**NOTICE:** This signal word addresses practices that could result in property damage but not personal injury.

#### Symbols/Labels on equipment



Caution: Indicates a hazardous situation which, if not avoided, could result in personnel injury and/or equipment damage.



Voltage level warning. Located on labeling for test leads on right side of instrument

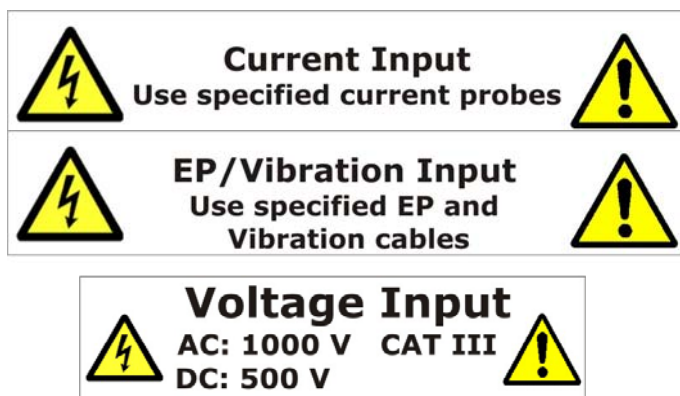

Fig Pre-1: Safety Labels from EXP4000

### Other Important Safety Warnings

- 5) **Warning:** When the instrument exterior case is open, the instrument is not water resistant. Do not allow the opened instrument to be exposed to water. Water in contact with the interior of the instrument compromises protection features and could result in serious injury or death.
- 6) **Warning:** Because of the voltages present, the test should be conducted only by trained personnel, and adequate safety precautions must be taken to avoid injury to personnel and damage to property.
- 7) **Warning:** Because of the dangerous currents, voltages, and forces encountered, safety precautions must be taken for all tests. Follow all corporate guidelines and those included here. Due to the wide diversity of machine applications, no attempt is made here to list or review all specific manifold general safety precautions. However, this manual includes special safety precautions applicable to the use of the EXP4000.
- 8) **NOTICE** The maximum rating of the EXP4000 is 1,000 V (500 V for DC operation). 1,000 V (500 V DC operation) is the maximum allowable voltage between any two of the four voltages and the ground clip. Under no circumstances connected the voltage sensing circuit to higher voltage levels, this will cause severe damage to instrument.
- 9) **NOTICE:** The maximum voltage rating of the EXP4000 DC current meters is 600 V. Under no circumstances connect the current sensors to circuits of any higher voltage, this will cause sever damage to instrument.

### Operational safety warnings

Baker Instrument Company, an SKF Group Company recommends the following safety precautions:

- 3) Comply with all your facility's safety practices at all times.
- 4) Make sure physical setup does not interfere with your facility's current or intended operation.

Additionally, these safety precautions must be followed, otherwise dangerous shock hazards may exist:

- 13) Use whatever safety equipment required by your organization including eye protection, high voltage gloves, arc-flash rated masks, hoods and any required PPC.



Prior to opening any MCC (Motor Control Cabinet), make sure that appropriate arc-flash protection clothing is worn.

- 14) Make sure that appropriate lockout / tag-out procedures are properly understood and implemented by all personnel.
- 15) **WARNING:** To minimize risk of electric shock, **every connection at MCC must be done while system is powered down.**
- 16) Depending on the kind of test to be run, make sure no physical proximity to the shaft of the motor or any other moving part of the machinery.
- 17) Make sure motor's phase connections are not positioned near ground or near each other.
- 18) Do not touch the connections, PT's, CT's or any component under test while a test is being made.
- 19) This product is grounded through the grounding conductor of the power cord if running on AC power.
- 20) Voltage ground clip must be connected to ground when the unit is running on battery power.
- 21) Remove the power cord from both the wall outlet and unit if it is running on battery power and not plugged into a wall outlet.
- 22) Do not coil power cord or test leads near motor leads.
- 23) During repairs, do not substitute any parts. Use only factory-supplied parts to minimize safety hazards.
- 24) This instrument is **NOT** approved for use in an explosive environment.

### Physical Setup of EXP4000 with portable sensors

- 1) Connect the voltage clip-ons to the voltage port on the EXP4000.
- 2) Connect the marked current clamp-ons to the current signal port on the EXP4000.
- 3) Turn on power to the laptop.
- 4) Double click the **EXP4000** icon to start the program.

### To connect the EXP4000 to the MCC

- 1) **WARNING:** To minimize risk of electric shock, make sure the motor is off. Open the panel of the MCC.
- 2) Connect a voltage clip-on to each phase of the breaker.
- 3) Attach one current clamp-on per phase.

Both the current and the voltage sensors of the EXP4000 are designed for low voltage. AC Voltage sensors are rated for 600 V DC. Voltage sensors are rated for 500 V. Attach Hall Effect CT's and DC Voltage Sensors for DC Motor testing applications. In order to measure medium or high voltage motors, CT's and PT's are required. In this case, the

current clamp-ons and voltage clip-ons have to be connected to the CT's and PT's on the customer's site.

**NOTE:** Make sure the current direction arrow points in the direction of the load when connecting current clamp-ons. Voltage clip-ons and current clamp-ons should be connected to the cold side of the breaker.

- 1) The voltage clip-ons and current clamp-ons should match color-wise on each phase. Ex. The yellow voltage clip-on should be attached to the same phase as the yellow current clamp-on.
- 2) Prior to energizing the motor exercise extreme caution to make sure that no terminals or clip-ons touch each other or touch ground. Energize the motor.

### To connect the EXP4000 to the motor terminals:

- 1) **WARNING:** To minimize risk of electric shock, make sure the motor is off.
- 2) Connect the current clamp-ons and voltage clip-ons to the terminal box.
- 3) **NOTE:** Make sure current direction arrow points in the direction of the load when connecting current clamp-ons.
- 4) The voltage clip-ons and current clamp-ons should match color-wise on each phase. Ex: The yellow voltage clip-on should be attached to the same phase as the yellow current clamp-on.
- 5) Attach one voltage sensor to each phase.
- 6) Exercise extreme caution to make sure that no terminals or clip-ons touch each other or touch ground when energized.

#### **Physical Setup of the EXP4000 with EP's**

**Note:** See Appendix D for installation instructions for EP's.

- 1) Connect the EXP4000 end of the mixed AD cable to the MCC port on the EXP4000.
- 2) Connect the other end of the mixed AD cable to the MCC plug.
- 3) Set the sensors option of the main panel to EP.
- 4) Click on run electrical.

### Disconnecting the EXP4000

- 1) **WARNING:** To minimize risk of electric shock, turn the motor off and allow it to de-energize.

### Connection setup wizard

#### Autophasing messages

When performing an electrical test on a line operated motor, one of two warnings may appear. The first warning will appear if Autophasing is not activated, and the EXP4000 realizes that the connection is mistaken (for example, having the current and voltage connections being in *acb* and *abc* sequence, respectively). The second warning will appear if Autophasing has failed due to excessive unbalances on the measured currents

or voltages. This can be from lacking one voltage signal, not having properly closed a CT.

Selecting yes will take the user into the connection setup wizard, continue test will continue testing using the physical setup, and abort test will stop the test without saving any information to the database.

## Using the setup wizard

Fig 9-2 shows the **setup connection wizard**. Become familiar with each labeled control. These need to be understood in order to adjust the setup correctly.

- 1) Current phasor controls
  - a. Controls the positioning of the phasors. Each dial will spin a current phasor around the voltage phasors at the measured values of all three CT's.

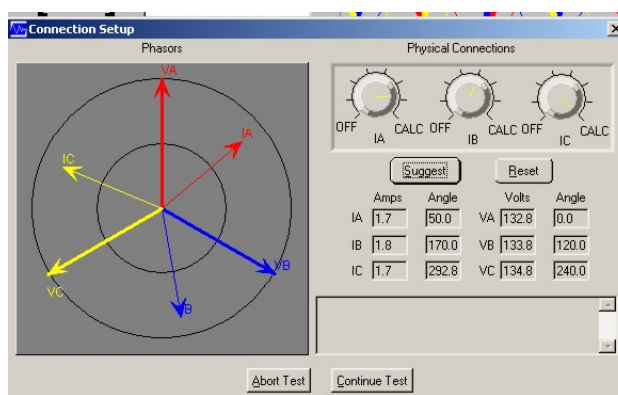

Fig 9-2: Connection setup

- 2) Phasor diagram
  - a. A visual interpretation of the setup for easier understanding of the necessary adjustments.
- 3) Warning box
  - a. Displays warning about current phasor setup. May indicate an improper setup.

<b>Troubleshooting CT connections</b>		
<b>Error</b>	<b>Reason for error</b>	<b>Possible resolution</b>
All Current Phasors should be 120 degrees apart	Current and voltage phasors should be 120 degrees apart (for example: $\text{abs}(I_a\text{-angle}-I_b\text{-angle}) \approx 120$ . Remember we are in a 360 degree system so using the above example: $I_b\text{angle} = 52.7 + 360.0$ $I_b\text{angle} = 412.7$ $I_a\text{angle} = 293.6$ $I_b\text{angle} - I_a\text{angle} = 119.1 \approx 120$ degrees	Rotate the Current phasor controls until all phasors have approximately a distance of 120 degrees +/- 5 degrees from each other.
CT Selection may be incorrect	The measured amps are below 10% of nameplate amps for the motor. Note that usually, the no load currents surpass the 30% of nameplate rating.	Verify that the correct CT selection was used when run electrical was pressed. If the CT Selection was incorrect the user will need to abort the test and correct the selection.
Red CT may be incorrect	$I_a\text{angle}$ should be between $V_a\text{-angle}$ and $V_a\text{angle} + 90$ degrees. Note that Induction Motors have the current lagging to the voltage. Note to neglect this warning, if the EXP4000 is connected to either a generator or a load with leading currents.	Rotate the $I_a$ current phasor dial until the red phasor is positioned correctly
Blue CT may be incorrect	$I_b\text{angle}$ should be between $V_b\text{angle}$ and $V_b\text{angle} + 90$ degrees. Note that Induction Motors have the current lagging to the voltage. Note to neglect this warning, if the EXP4000 is connected to either a generator or a load with leading currents.	Rotate the $I_b$ current phasor dial until the red phasor is positioned correctly
Yellow CT may be incorrect	$I_c\text{angle}$ should be between $V_c\text{angle}$ and $V_b\text{angle} + 90$ degrees. Note that Induction Motors have the current lagging to the voltage. Note to neglect this warning, if the EXP4000 is connected to either a generator or a load with leading currents.	Rotate the $I_c$ current phasor dial until the red phasor is positioned correctly
Warning - Load estimate is unusually high, phasor setup may be incorrect.	Estimated percent Load is $\geq 300\%$ . There may be a more practical solution with a reasonable load point.	Rotate current phasors until all are correct and load estimate is roughly where the motor is running.

## Setup wizard/Suggest button

### The Suggest button:

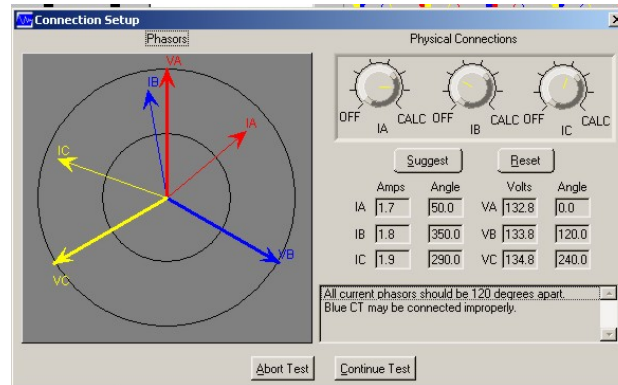

Fig 9-3: Suggest button

When the connection setup wizard appears the Suggest button is available. The Suggest button's purpose is to offer reasonable solutions in error mitigation (see Fig: 5-2). If there is more than one realistic solution the user will be prompted about load level. A selection of a high load scenario (90% and higher) or a low load scenario (20% and lower) can be made. This dialog rarely pops up. **Note:** This high load and low load scenario may be an indication of incorrectly entered nameplate data.

### Two CT solution:

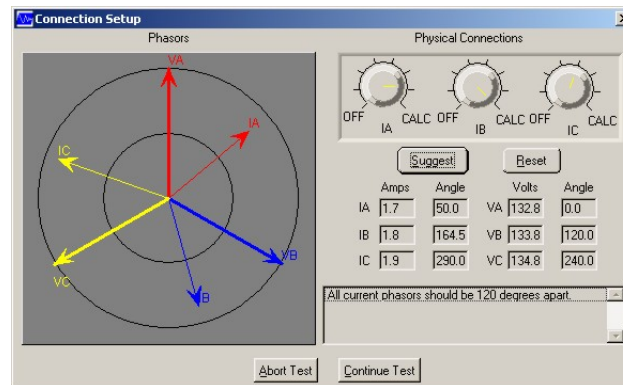

Fig 9-4: Connection setup

**The two CT solution is based on Kirchhoff's law of currents: The sum of currents into a node is equal to zero. Note:** Calculating the current of the third phase is only valid while there is no noticeable ground current, so  $I_a + I_b + I_c = I_G = 0$ . This is typically the case; however, a high impedance ground system with one grounded phase is an exception.

A 2 CT setup is needed if unable to physically connect all three CT's, if all three CT's are connected but one did not close or it is connected to a wrong wire, etc. If 2 or more CT's are not connected then the test should be aborted and the CT's manually adjusted.

In Fig 9-5, the blue CT is disconnected and an electrical test is performed. Notice the amplitude is zero. However, if the CT is not totally closed then phasor will be greater than zero but noticeably less than the other CT's.

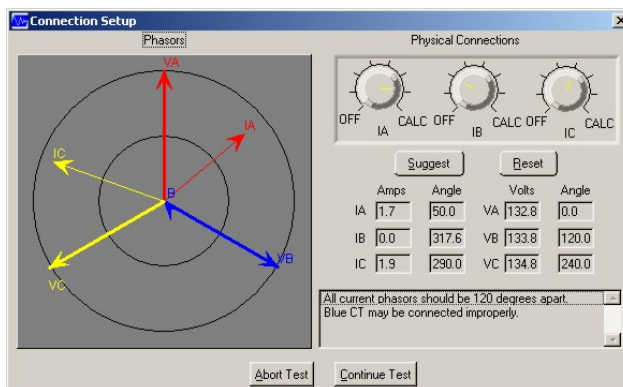

Fig 9-5: 2 CT physical connection

In Fig 9-6, there are several problems with the phasor setup. Notice the warnings: Red CT may be connected improperly and yellow CT may be connected improperly. In the above position,  $I_a$  is roughly where  $I_b$  should be, and the yellow phasor is roughly where the red phasor should be. Please note that although the blue CT was the one disconnected, the yellow CT is the one that needs to be calculated. This is because within the physical setup, the red CT was connected where the yellow CT should have been, the yellow CT was connected where the blue CT should have been, and the blue CT was disconnected. The Suggest button will be helpful in sorting through setup problems.

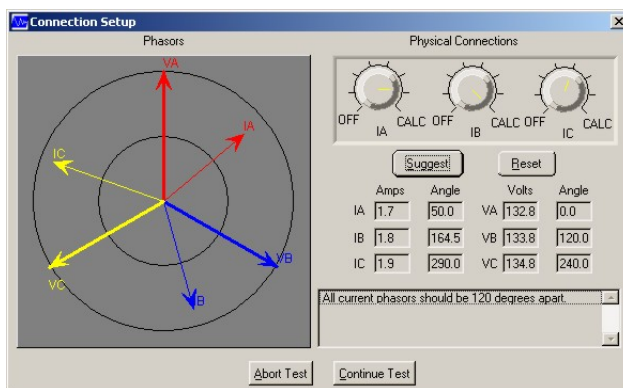

Fig 9-6: Phasor Connection

### Manually adjusting phasors:

Manually adjusting the phasors can quickly become confusing. If the Suggest button does not provide a solution, or if there is not a unique setup, then manually adjusting the phasors may be needed. Adjustments are exactly the same as adjustments made in the MCC in order to properly connect the EXP4000. There are two rules in adjusting phasors:

- 1) All Phasors (currents and voltages) should have an angle between them of  $120 \text{ degrees} \pm 5$ .
- 2) For all induction motors, the current phasor must follow the voltage phasor by a maximum of  $90 \text{ degrees}$ .

Fig 9-7 is a diagram of all phasor positions. All three current phasors must be in the same area in order for the setup to be correct. For example if the  $I_a$  phasor is in the high load position,  $I_b$  and  $I_c$  must also be in the high load position. The dark shaded are non-phasor positions. Although this can be done mathematically, no phasors can physically reside in the dark shaded, for three phase induction motors without PF correcting devices.

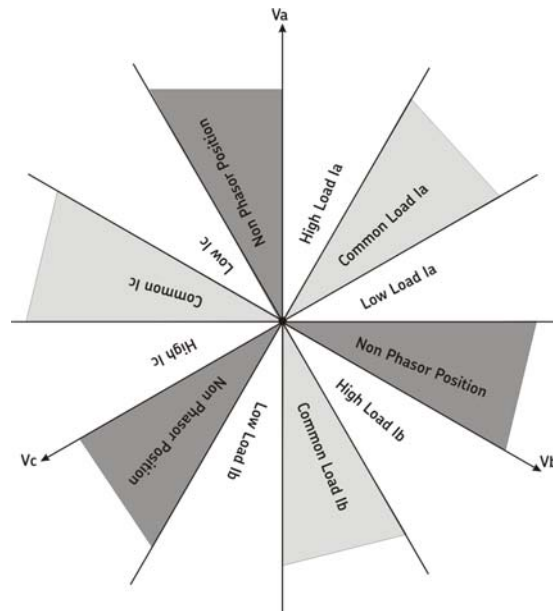

Fig 9-7: Phasor Diagram

There is the possibility that phasors can reside in the high load position or be rotated 180 degrees and be in the low load position. In order to minimize potential errors, we have provided a load estimate. If the phasors are setup in the high load position and the load estimate is 300 percent or higher, then the most likely correct solution is to rotate the phasors to the low load position. (Note: to go from a high load position to a low load position: rotate each dial one position to the left. To go from a low load position to a high load position: rotate each dial to the right one position.)





# Example test and report generation

---

This chapter is to give general guidelines for using the EXP4000 dynamic motor monitor. It does not cover all capabilities of the machine.

## Important safety information

### General Safety Precautions

**Note:** The general safety information presented here is for both operating and service personnel. Specific “warnings” and “cautions” will be found throughout this manual where they apply.

**Note:** If the equipment is used in any manner not specified by Baker Instrument Company, an SKF Group Company, the safety protection provided by the equipment may be impaired.

### Safety term definition

**DANGER:** Indicates a hazardous situation, which, if not avoided, will result in death or serious injury.

**WARNING:** Indicates a hazardous situation, which, if not avoided, could result in death or serious injury.

**CAUTION:** Indicates a hazardous situation, which, if not avoided, could result in minor or moderate injury.

**NOTICE:** This signal word addresses practices that could result in property damage but not personal injury.

## Symbols/Labels on equipment



Caution: Indicates a hazardous situation which, if not avoided, could result in personnel injury and/or equipment damage.



Voltage level warning. Located on labeling for test leads on right side of instrument

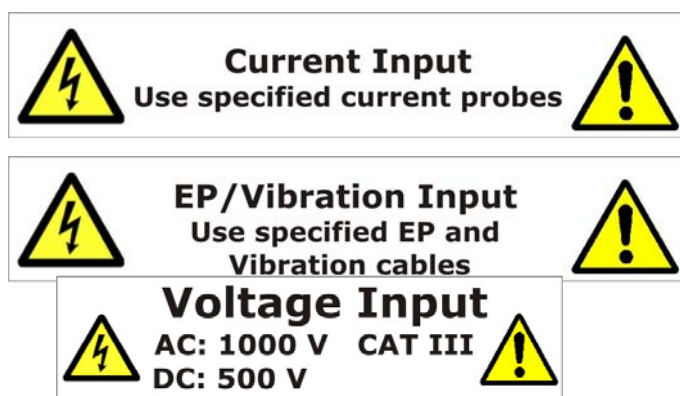

Fig 10-1: Safety Labels from EXP4000

### Other Important Safety Warnings

- 10) **Warning:** When the instrument exterior case is open, the instrument is not water resistant. Do not allow the opened instrument to be exposed to water. Water in contact with the interior of the instrument compromises protection features and could result in serious injury or death.
- 11) **Warning:** Because of the voltages present, the test should be conducted only by trained personnel, and adequate safety precautions must be taken to avoid injury to personnel and damage to property.
- 12) **Warning:** Because of the dangerous currents, voltages, and forces encountered, safety precautions must be taken for all tests. Follow all corporate guidelines and those included here. Due to the wide diversity of machine applications, no attempt is made here to list or review all specific manifold general safety precautions. However, this manual includes special safety precautions applicable to the use of the EXP4000.
- 13) **NOTICE** The maximum rating of the EXP4000 is 600 V (500 V for DC operation). 600 V (500 V DC operation) is the maximum allowable voltage between any two of the four voltages and the ground clip. Under no circumstances connected the voltage sensing circuit to higher voltage levels, this will cause severe damage to instrument.
- 14) **NOTICE:** The maximum voltage rating of the EXP4000 DC current meters is 600 V. Under no circumstances connect the current sensors to circuits of any higher voltage, this will cause sever damage to instrument.

### Operational safety warnings

Baker Instrument Company, an SKF Group Company recommends the following safety precautions:

- 5) Comply with all your facility's safety practices at all times.
- 6) Ensure physical setup does not interfere with your facility's current or intended operation.

Additionally, these safety precautions must be followed, otherwise dangerous shock hazards may exist:

- 25) Use whatever safety equipment required by your organization including eye protection, high voltage gloves, arc-flash rated masks, hoods and any required PPC. Prior to opening any MCC (Motor Control Cabinet), ensure that appropriate arc-flash protection clothing is worn.
- 26) Ensure that appropriate lockout / tag-out procedures are properly understood and implemented by all personnel.
- 27) **Every connection at MCC must be done while system is powered down.**
- 28) Depending on the kind of test to be run, ensure no physical proximity to the shaft of the motor or any other moving part of the machinery.
- 29) Ensure motor's phase connections are not positioned near ground or near each other.
- 30) Do not touch the connections, PT's, CT's or any component under test while a test is being made.
- 31) This product is grounded through the grounding conductor of the power cord if running on AC power.
- 32) Voltage ground clip must be connected to ground when the unit is running on battery power.
- 33) Remove the power cord from both the wall outlet and unit if it is running on battery power and not plugged into a wall outlet.
- 34) Do not coil power cord or test leads near motor leads.
- 35) During repairs, do not substitute any parts. Use only factory-supplied parts to minimize safety hazards.
- 36) This instrument is **NOT** approved for use in an explosive environment.

## Motor monitoring

Prior to testing, the software must be set up with database structures, machines must be accurately input and all thresholds for each test must be established. See Chapter 3 Basic software overview for procedures.

After this is done, the EXP4000 must be hooked-up to the machine to be tested. Review Chapter 9 Physical connection of the EXP4000/Connection setup wizard.

- 1) After hookup is accomplished click on the check connections button located on the main screen of the software.
- 2) If the connections are not correct and the machine is not a VFD machine the autophasing will automatically correct the connections.
- 3) If the machine is a VFD machine, autophasing is automatically turned off. The connections must be manually corrected. See Chapter 9 for assistance.
- 4) Click Run Electrical. This will run all pre-programmed settings for the machine in question.
- 5) When testing is done, scan the front panel results for accuracy. If all is fine, write the testing to the database.



## Looking at gathered data

It is important to look at the data gathered prior to writing it to the database. If the data is deemed to not be good, it can lead to misinterpretation of results. Parameters can be adjusted and the testing redone if the front panel results are not reasonable for the machine.

### *Adjusting parameters*

If the torque – speed curve has a red dot appearing in the graph area it can be from a speed miscalculation, rotor bar problems, an incoming voltage problem or another cause. Check the speed in the nameplate.

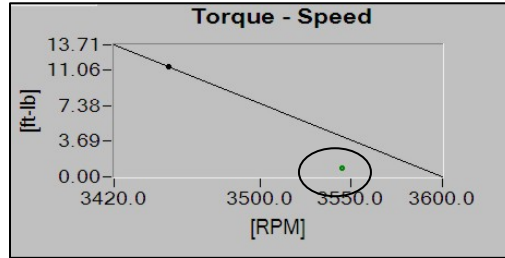

Fig 10-2: Torque-speed graph from main panel

If the current draw is incorrect check the CT selection from the front panel or the connections button. The physical connection may not be right or there is a bad connection.

**Other adjustments**

There are a few adjustments within the Options menu dropdown.

**Override speed**

If the speed is wrong, it can be overridden. Click Options, the override speed. Move the toggle arrow to the on position and then input the appropriate speed.

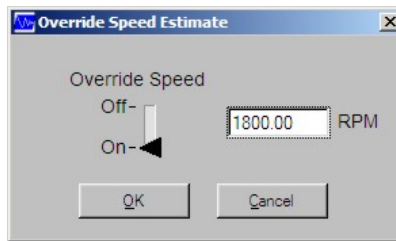

Fig 10-3: Override speed

**Adjust electrical acquisition time**

This will affect absolute test time and increase rotor bar test resolution. If rotor bar problems are suspected, it can be helpful to increase the acquisition time to obtain more data.

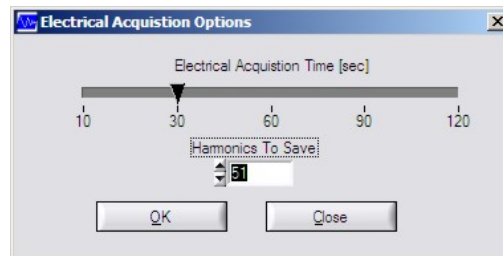

Fig 10-4: Electrical acquisition options

### Spectrum acquisition options

This adjustment allows the user to change the frequency range being monitored along with the resolution. This affects the voltage, current and the torque spectrums.

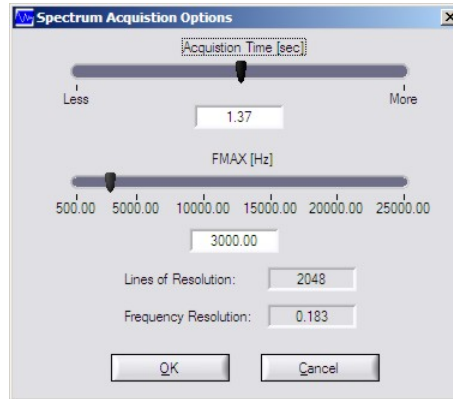

Fig 10-5: Spectrum acquisition options

### Looped acquisition/Timed acquisition

In the tools menu there are two types of acquisition modes. Either looped or timed. The continuous looped acquisition mode ensures the user of some piece of mind in gathering good data because of a set amount of tests that must be completed prior to the instrument stopping. It is recommended that a minimum of 5 tests be done with 10 being an optimal amount.

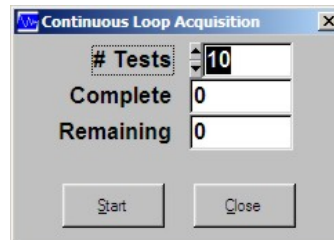

Fig 10-6: Continuous loop acquisition

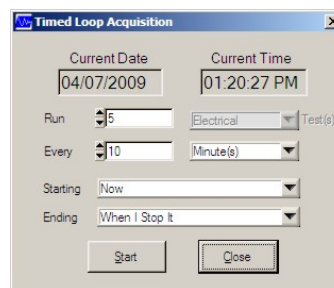

Fig 10-7: Timed acquisition

The second acquisition mode is timed. This mode is based on time and date as the trigger.

### Creating reports from the report generator

- Only machines with a stored result can generate a report.
- User can select multiple machines and results to generate a report.

## Example test and report generation

- Select the results to be included on the report by placing a check next to the result in the tree.
- A machine summary page is automatically generated for each unique machine that is being included in the report.
- Click on the Filter On tool button to toggle filtering of the results on and off.

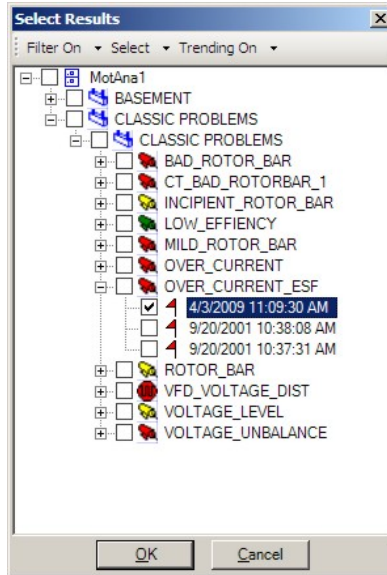

Fig 10-8: Report generator

- o Using the Filter sub-menu filter the displayed results by result status or by a specific data range.

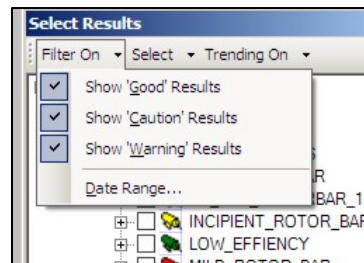

Fig 10-9: Reports - filter on

- Click the Select toolbar to select all of the displayed results for reporting.
  - o Using the Select sub-menu, automatically select results based on result status.
- Click the trending on button to view trending parameters. By clicking on the word Trending On it will change to Trending Off.

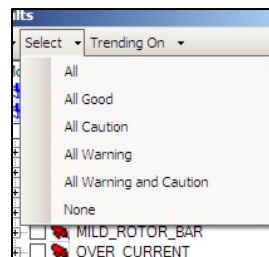

Fig 10-10: Reports - select

- Click on Ok after all parameters for the report have been developed. The report wizard will now create the report the user can save it as a .rtf type file. It can then be reviewed in an assortment of software.

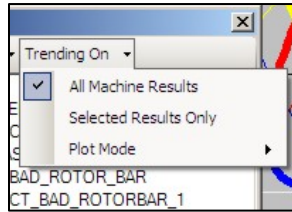

Fig 10-11: Reports - trending on

### Viewing, annotating, and printing reports

After the report has been generated via the wizard, the report will automatically create and auto fill into a .rtf (Rich Text File) document. This document can be edited to suit the users needs (i.e. logos, notations of tests, network capable, etc.) These annotations can be made in the report through normal text editor functionality.

### Automatic generation of reports

Results for tests conducted with the EXP4000R are automatically saved. Reports can be generated from this data, providing pass/fail data, numeric data, and appropriate waveforms from tests. Charts trend this data, which is logged with test dates. Analysis of test results over time is a key tool in a predictive maintenance program.

### Printing reports directly from results panel (single report)

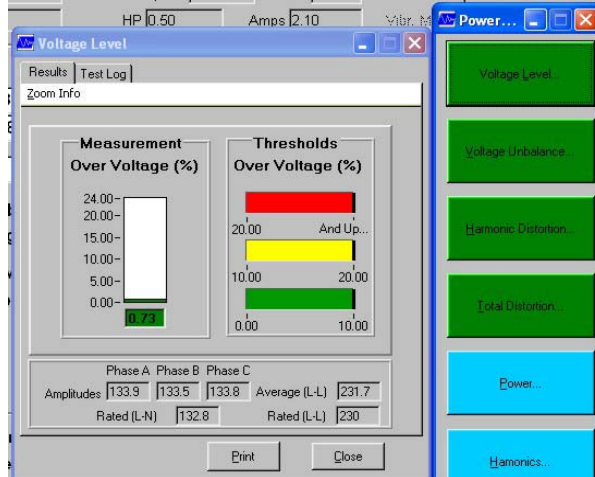

Fig 10-12: Single report generation

- 1) Click on test domain button wanted. (i.e. power quality, machine performance, current, spectrum, torque, connections, VFD details or vibration (if option available).
- 2) Press desired test button for the test wanted. (For this example the power condition domain is being selected. (i.e. voltage level, voltage unbalance, harmonic distortion, total distortion, power and harmonics).
- 3) Press print.

### Printing reports from the summary page

- 1) Click file and then print summary report. The summary report dialog box will pop up.
- 2) Click in each of the print test toggle boxes that are needed to print.
- 3) Click print.

**Machine Performance Report**

**Baker** **EXPLORER** Time/Date: 12/12/2002 11:39:53 PM

Database: test Test Model: default elec

Location: Basement Memo: \_\_\_\_\_

Building: Alamo Test By: \_\_\_\_\_

Machine: default Test For: \_\_\_\_\_

Serial No.: 200

HP: 0.50 Manufacturer: \_\_\_\_\_

KW: 0.37 RPM: 1725

Volts: 230 Amps: 2.10

Serv. Fact.: 1.25 Stator Res. (L-L): 32.00E+0 Ohms

Frame: \_\_\_\_\_ Insulation: F

Speed [RPM]: 1747.9 Torque Ripple [%]: 14.90 Load [%]: 98.7 Efficiency [%]: 75.0

Test	Value	Caut. Level	Warn. Level	Status
Over Voltage	0.73	10.00	20.00	Good
Voltage Unbalance	0.18	2.00	3.50	Good
Harm. Distortion	0.95	7.00	9.00	Good
Total Distortion	2.13	10.00	12.00	Good
Over Current	90.09	110.00	120.00	Good
Eff. Serv. Factor	0.99	110.00	125.00	Good
Rotor Bar	-60.29	-45.00	-36.00	Good
Op. Condition	0.00	20.00	30.00	Good
Losses	0.20	N/A	N/A	N/A
Payback	0.00	N/A	N/A	N/A

Main Panel       Energy Assessment  
 Power Condition Report       Machine Performance Report  
 Machine Condition Report       Load Reports

Print Cancel

Fig 10-12: Print summary report

**Note:** If there is more than one report within the domain chosen, they will automatically print in order.

Printed reports can be placed on letterhead or other print materials to obtain a professional written report.



# Appendix A

## Default settings

---

- Database Directory [InstallDir]\dB
- Archive Directory [InstallDir]\Archives
- EP Acquisition – Find Machine Associated with EP & Auto Assign it
- Elec Acquisition Options: 10 Sec. (**Note:** 2 Pole Machines are always acquired with at least 30 seconds despite this setting).

### Default settings

Test		Yellow	Red
Electrical	Voltage Level		
	Overvoltage	10%	20%
	Under Voltage	5%	10%
	Unbalance	3%	5%
	Distortion	5%	8%
	Rotor Condition	45 dB	36 dB
	Operating Condition	5%	10%
	Service Factor	1	1.1
	Over Current	100%	110%
	Efficiency	5%	10%
	Payback Period	24 Mo.	12 Mo.
	Spectrum Acquisition	3000 FMax	1.37 Acq Time
Vibration	Vibration (in/sec)	0.15	0.35
	Operating Condition	10%	20%
Machine Tree	Tree Level 1 Name	Location	
	Tree Level 2 Name	Building	
Units	US Customary		
Currency	Dollars (\$)		
Voltage	Line to Ground		
Machine Tree Filters	Show Machines with No Tests		
	Show Tests with a Good rating		
	Show Tests with a Caution rating		
	Show Tests with a Warning rating		
	Do <b>Not</b> Filter test by Date		



# Appendix B

## Troubleshooting

### Connection troubleshooting

---

#### General

The EXP4000 has 2 different modes of operation: Non-VFD (60Hz or 50Hz line operated) or VFD (Variable Frequency Drive mode). The requirements for either of these modes are slightly different from a connection standpoint of view. For VFD connection troubleshooting, please see Chapter 5.

#### Non VFD mode:

This mode is operated in two different ways, with or without autophasing. Autophasing allows for automatic correction for proper phasing of the current transformers (CT's) with respect to the connected voltage phases. The autophasing feature is designed to recognize which CT's signal belongs with which polarity, and to which connected voltage signal. It requires that the observed three-phase load be *only an induction motor without power factor correction downstream of the point of connection*. If any other device is being observed, the autophasing feature needs to be turned off.

Non-VFD, Autophasing feature ON:		
Issue	Possible cause	Action
Monitored speed is wrong	The device connected is either not a 3 phase induction motor, or there are power factor correcting capacitors down the line from the point of connection	Turn the autophase feature off and be aware that portions of the data (incl. speed, torque, rotor bar, efficiency) are compromised.
Motor is running at high load, yet EXP4000 is displaying low load	Autophasing failed. (Rare)	Turn autophasing feature off, ensure proper phasing in connection, save data and send to Baker Instrument Company, an SKF Group Company for further tuning of autophasing feature.
Motor is running at no load, yet EXP4000 is displaying a high load	Autophasing failed. (Rare)	Turn autophasing feature off, ensure proper phasing in connection, save data and send to Baker Instrument Company, an SKF Group Company for further tuning of Autophasing feature.

Non-VFD, Autophasing feature OFF:		
Issue	Possible cause	Action
Note that <i>V- and I- sequence do not coincide</i>	Voltage is connected in abc and current in acb sequence, or vice versa.	Swap two CT connections. (Example: swap the red CT and the yellow CT's location.
Three power factors (details, power) are negative or <i>load is very wrong</i> (Far too high or far too low)	CTs are <ol style="list-style-type: none"> <li>facing the wrong direction</li> <li>connected to the wrong phase</li> </ol>	<ol style="list-style-type: none"> <li>Turn the three CTs around. (Reverse direction of arrow)</li> <li>Exchange cyclical locations of CTs (red to yellow, yellow to blue, blue to red). If results still not correct, perform this step one more time. Otherwise check a).</li> </ol>

### Frequently Asked Questions:

- The EXP4000 shows the wrong speed. It displays the operating speed as synchronous speed (3600rpm, 1800rpm, 1200rpm, 900rpm, etc for 60Hz or 3000rpm, 1500rpm, 1000rpm, etc for 50Hz operation). However, the motor is running at speeds lower than that. What is the problem?

When creating a new machine, the nameplate speed needs to be entered into the speed field of the **Create Machine**, or **Edit Machine** panel. If the synchronous speed was entered, then the EXP4000 expects to be testing a synchronous machine, and not an induction machine. For a synchronous machine, displaying the synchronous speed is correct.

- 1) Click on machine, edit machine.
- 2) Enter a new name into the machine name field. Click apply. A screen will popup saying "Machine Name has changed. Create a New Machine? Select no to update the existing machine.
- 3) Click either yes.
- 4) All nameplate fields will now become editable. Make changes as appropriate and click Apply. This will create a new machine without any test data.
- 5) In order to view this new machine, click on Machine and then Machine Tree.
- 6) Click on View and then Reload. This will load the new named machine into the tree.
- 7) Click on the machine and perform tests again.

**Note:** An existing machine with recorded tests cannot be edited. In order to edit this machine, the user must delete all tests and then edit the machine.

- **How do I connect** the EXP4000 to the secondaries of PT's if I have an open delta configuration?

Open Delta configurations are the most common case in the field for medium or high voltage motors.

- 1) Ensure all safety precautions are being followed, when working with live voltage. See Preface for safety precautions.
- 2) Identify the three different points in the MCC that show the same voltage (typically 100V – 200V) when connecting A-B, B-C, C-A. One of these pins typically is the ground pin.
- 3) Clip the ground connection to a viable ground in the MCC. Note that commonly, this will be one of the three pins that was previously identified.
- 4) Connect the three phase clipons to each one of the pins that was identified.

- How do I connect the EXP4000's portable CT's **if I have only 2 CT's installed** in my medium or high voltage motor?

The concept of sum of currents applies in this situation.

- 1) Connect the first two portable CT's to phases *A* and *B*.
- 2) The third CT needs to be connected to both CT's around the other phases. Make sure that the third CT totally closes around both currents of phases *A* and *B*. If the CT doesn't totally close, it will monitor much less current.

**Note:** The third CT needs to be monitoring the **SUM** of both currents, and not the subtraction. This means that the orientation of the wires through the CT has to be such that the currents add and do not subtract. If the wires are set such that the currents subtract, the EXP4000 will monitor a very high current unbalance through that CT. If this is the case, take one of the two wires out of the CT; and introduce it into the CT in the opposite direction with respect to the CT's arrow.



# Appendix C: Blue results

---

## Conditions under which test show blue results:

Blue results are results that have no threshold comparison but give valuable information about the machine.

Voltage level	Always for VFD mode. Never in Non-VFD mode
Rotor bar	Low load (below 25%) Varying frequency during acquisition High noise floor of many current components Slip frequency is not separated enough from fundamental (Try higher acquisition settings)
Efficiency	No entry of stator resistance No comparable motor found in database
Payback period	Efficiency blue condition Missing data of a least one of the following: Hours per day Days per year \$ per kWh
Torque ripple	Always
Details (all)	Always
Current Imbalance	Load <= 25





# Appendix D

## EP1000 installation

---

To obtain complete installation drawings and templates, please contact Baker Instrument Company, an SKF Group Company and ask for document number: 71-028

### **What to do first:**

Please verify all needed materials are in package:

- EP1000
- 3 CTs
- Terminal block cover and hardware
- MCC cable
- EP mounting hardware
- Template for EP enclosure mounting.

### **Tools Needed:**

- Small flathead screwdriver
- Pencil or felt-tip pen
- Phillips Screwdriver
- Hand drill
- Set of Drill bits
- Greenlee 2-1/2" punch.

### **Materials Needed:**

- Switchboard wire, SIS #14, 600 V
- Wire lugs, 14-16 AWG, #8
- Splice sleeves 14-16 AWG
- Ty-wraps, T&B 7"
- Wire, #14, 600 V color green (Ground Connection)
- Control Cable, 3/C #14 AWG, 600 V, EPR/CPE
- Tag Book, ABC (T&B)
- Fuse Block (PT) 600 V/2 Amp

## Safety Precautions for EP installation



**DANGER:** To prevent serious injury or death cabinet voltage must be de-energized for installation.

- 15) **WARNING:** Because of the dangerous currents, voltages, and forces encountered, safety precautions must be taken for all tests. Follow all corporate guidelines and those included here. Due to the wide diversity of machine applications, no attempt is made here to list or review all specific manifold general safety precautions. However, this manual includes special safety precautions applicable to the use of the EXP4000.
- 16) **NOTICE:** The maximum rating of the EXP4000 is 1,000 V (500 V for DC operation). 1,000 V (500 V DC operation) is the maximum allowable voltage between any two of the four voltages and the ground clip. Under no circumstances connected the voltage sensing circuit to higher voltage levels, this will cause severe damage to instrument.
- 17) **NOTICE:** The maximum voltage rating of the EXP4000 DC current meters is 600 V. Under no circumstances connect the current sensors to circuits of any higher voltage, this will cause severe damage to instrument.

### Installation safety warnings

Baker Instrument Company, an SKF Group Company recommends the following safety precautions:

- 7) Comply with all your facility's safety practices at all times.
- 8) Ensure physical setup does not interfere with your facility's current or intended operation.

Additionally, these safety precautions must be followed, otherwise dangerous shock hazards may exist:

- 37) Use whatever safety equipment required by your organization including eye protection, high voltage gloves, arc-flash rated masks, hoods and any required PPC. Prior to opening any MCC (Motor Control Cabinet), ensure that appropriate arc-flash protection clothing is worn.
- 38) Ensure that appropriate lockout / tag-out procedures are properly understood and implemented by all personnel.
- 39) Ensure motor's phase connections are not positioned near ground or near each other.

### Hardware Installation

**NOTE:** It is necessary that each EP is provided 3 phase voltage (not in excess of 1,000 V AC) and a good ground. Some switchgear installations will require this voltage to be wired from the bus cabinet to each cabinet being outfitted with an EP. For motors rated at voltages higher than 1,000 V AC, secondary output voltage from the PT's are acceptable as long as all three phases are present as line to line voltages, and are lower than 1,000 V AC.

### Choosing a suitable location for the EP:

The EP may be mounted in a variety of locations as long as the following criteria are met.

- 1) The EP must be installed in a cabinet or enclosure that is secured with a tool or key lock.
- 2) Voltage and Current lines can be easily and safely ran to the EP in accordance with applicable electrical codes.
- 3) The connector cable can reach the cabinet door, and the movement of the door is not restricted.
- 4) The EP does not interfere with or complicate the mechanical operation of the cabinet (i.e. doors opening, terminal blocks covered, slide rack interference).
- 5) The physical location of the EP does not cause an electrical, environmental, or safety hazard.
- 6) An Earth ground from the motor cabinet to the EP ground stud is installed.

The EP may be affixed to the interior of the cabinet by any means deemed appropriate; however, it is recommended that a positive mounting system such as metal screws be utilized. Supplied with the EP is a mounting template for the enclosure, as well as self tapping metal screws. The template is a 1:1 representation of the EP enclosure, and can be used for location assessment as well as mounting hole placement. Once the location is decided:

- 1) Mark the mounting holes from the template to the cabinet.
- 2) Remove the template.
- 3) Drill the mounting pilot holes.
- 4) The EP enclosure may now be mounted to the cabinet with the screws provided.

### Choosing a suitable location for the panel plug:

The panel plug is to be mounted on the door of the cabinet. The location should be easily accessible from the outside of the cabinet, providing the user an easy and obvious hookup scheme. Once the location is decided:

- 1) Mark the center hole to the cabinet.
- 2) Drill the center hole.
- 3) Using whatever means deemed appropriate, remove the center cutout. It is recommended a 2- $\frac{1}{2}$ " Greenlee style punch be used to create the cutout.
- 4) Once the cutout is removed, place the plug over the hole, and mark the four mounting holes.
- 5) Remove the plug, and drill the four outer mounting holes.
- 6) Mount the plug and the backplate using the supplied hardware.
- 7) Provide strain relief for the cabling attached to the panel plug.

### Current Transformer (CT) Connections:

- 1) Verify that all three CTs are marked with the same bin number; this is a number between 1 and 5.
- 2) The supplied CT donuts are to be placed on the three voltage feeds to the motor.
- 3) These should be placed on the **load-side** of any line protection devices (circuit breakers). **Care should be taken to ensure the dots on the CTs point toward the load (motor)**. Red is phase A, blue is phase B, and yellow is phase C.
- 4) The Baker CTs should be installed on the output of existing CTs in the system for all motors operated at voltages above 1,000 V. Check that the output of the secondary is less than or equal to the rating of the Baker CTs.
- 5) Ensure there is enough wire length to connect to the EP. If installed CTs are used, be sure to note the ratio, as this information will be needed when creating a motor ID.

## Voltage Connections:

**NOTE:** On motors with input voltages higher than 1,000 VAC it will be necessary to make the connection after a Power Transformer (PT) located between the voltage source and the EP.

Three-phase voltage should be connected to the EP once it is installed. Installing a fuse block near the EP, connected in-line between the EP and the voltage source, is recommended. Ensure there is enough wire length to connect to the EP.

## Electrical Connections:

Once the EP has been mounted, CTs have been installed, and three-phase voltage lower than 1,000 VAC is made available, the electrical connections may be made.

- 1) Connect the three CT twisted pairs to the EP current terminal block corresponding to the appropriate phase, marked Ia, Ib and Ic (from right-to-left); white wire on the right and black wire on the left for each phase. Tightening torque is 0.5 N-m.
- 2) Connect the three voltage leads to the EP voltage terminal block corresponding to the appropriate phase, marked Va, Vb and Vc, being sure to **connect a ground to the ground position of the voltage plug**. Tightening torque is 9 in-lb. **Additionally, the MCC ground should be connected to either of the ground studs on the EP enclosure.**

**Caution:** Make sure that the voltage wiring for each phase is completely captured by its corresponding phase in the EP voltage plug (i.e. No wire strands poking out)

- 3) Mount the cover over the top of the voltage terminal block by either using the supplied screws and nylon spacers (plexiglass cover only), or by snapping in place. For the plexiglass cover, the screws thread directly into mounting holes in the EP case, 0.437 inches above and below the top and bottom voltage terminal block mounting screws, respectively.
- 4) Connect the MCC cable (the end opposite the panel plug) to the A/D Bus DB25 receptacle of the EP, and secure in place with the captive screws.
- 5) Provide strain relief for all current and voltage wiring, as well as the DB25 cabling at the EP enclosure.

## Verification of Installation:

- 1) Energize cabinet
- 2) Connect umbilical cable between Explorer and EP panel plug.
- 3) Open the Explorer software and create a new motor id.
- 4) Set Sensors switch to EP position
- 5) Press Run Electrical button

## Troubleshooting:

### EP1000 Ratings:

- Voltage Terminal: 1,000 V AC, CAT III
- Current Terminal: Use Specified Current Transformers
- A/D Bus Connector: Use Specified Umbilical Cable
- Input: 5 V DC 105 mA
- Connect Only to EXP4000 or Similar

No voltage signature	Replace EP fuses
MCC Sensor Error	Verify all connections between EP and Explorer
Autophasing not successful – or – V – sequence does not match I – sequence	Verify correct voltage and current hookup. Verify arrows on CT's point toward load.
EP not associated with a Motor ID	Follow procedure "To associate an EP with a Motor ID.
Voltages and/or currents are too small	Check correct sensor ratios

# 1,000 V Bus and Below Connection Scheme

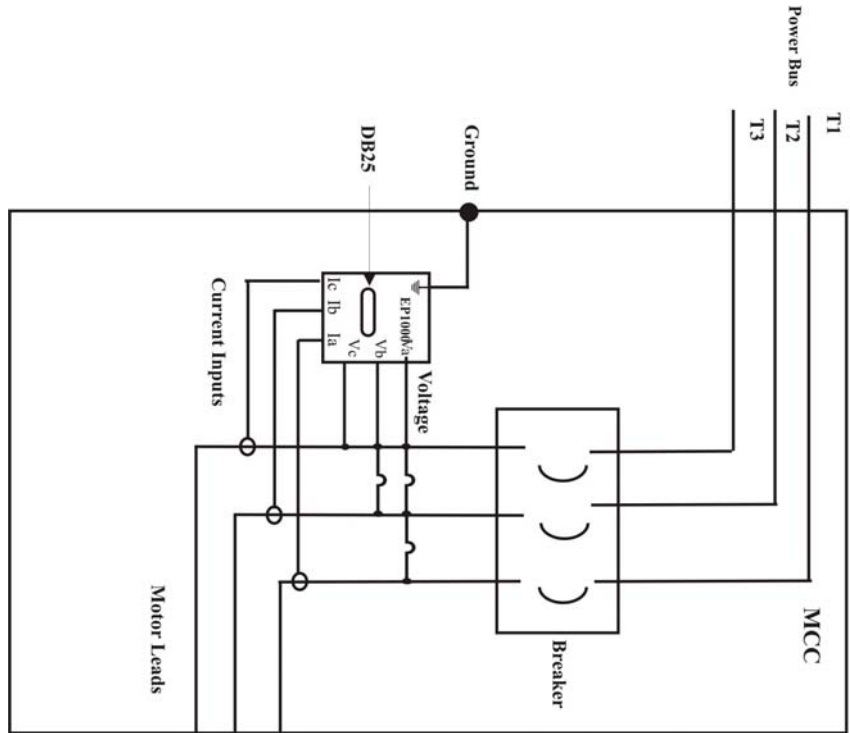

Notes:  
 1. For medium and high voltage motors, Voltage Inputs are to be connected to the PTs the following way:

- a. Three phases are to be connected to the hot secondaries (120V typical) and to the ground respectively.

2. For medium and high voltage motors the Baker CT donuts are to monitor the secondary of the CTs (5A typical) in the MCC.

3. For monitoring of VFD motors, the electrical connections are to be made between the motor and the output of the VFD.

4. In any connection above, the EP-MCC cable is to be connected to the DB25 of the EP1000. The other end of the EP-MCC Cable is to be panel mounted to the exterior of the MCC.

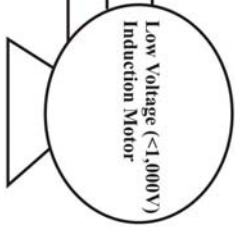

### 3CT, 2PT Connection Scheme

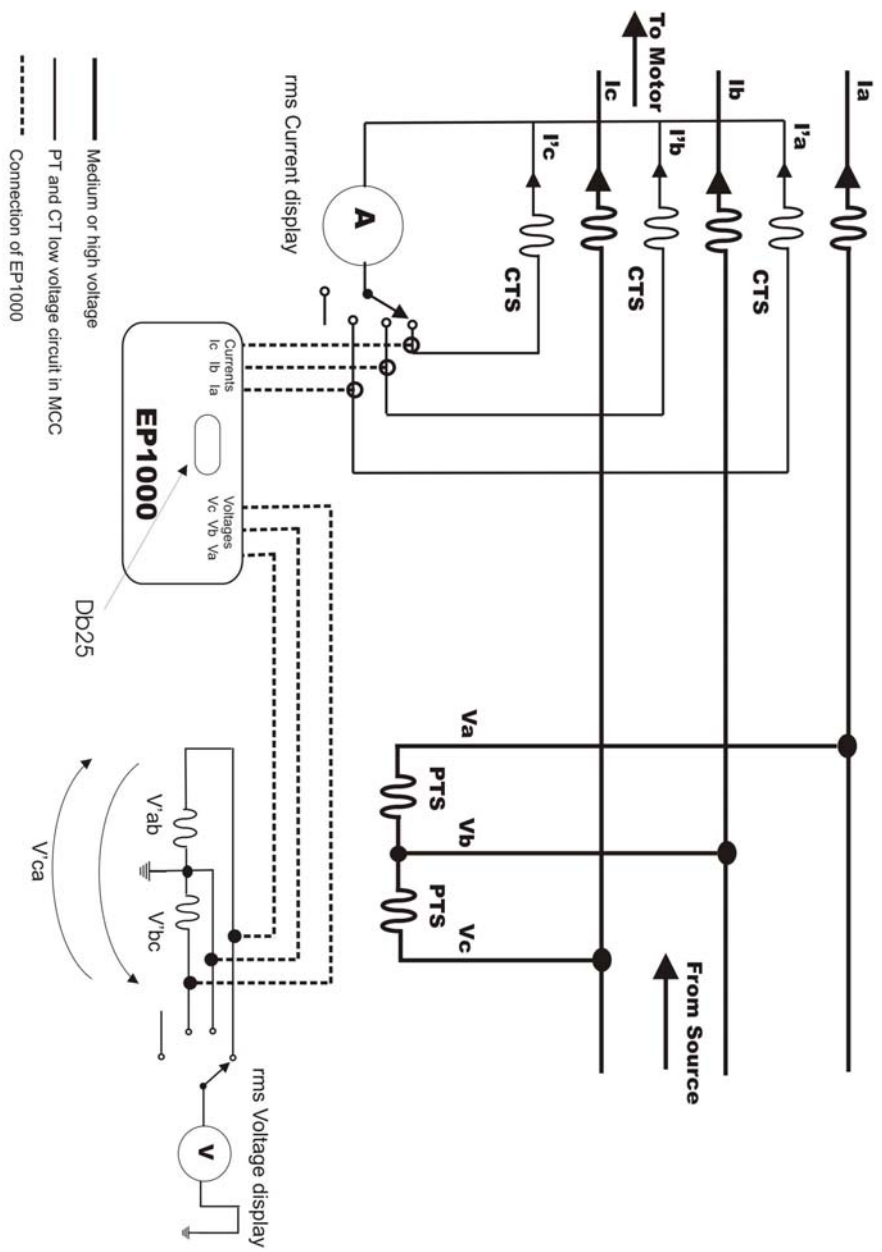

## 2CT, 2PT Connection Scheme

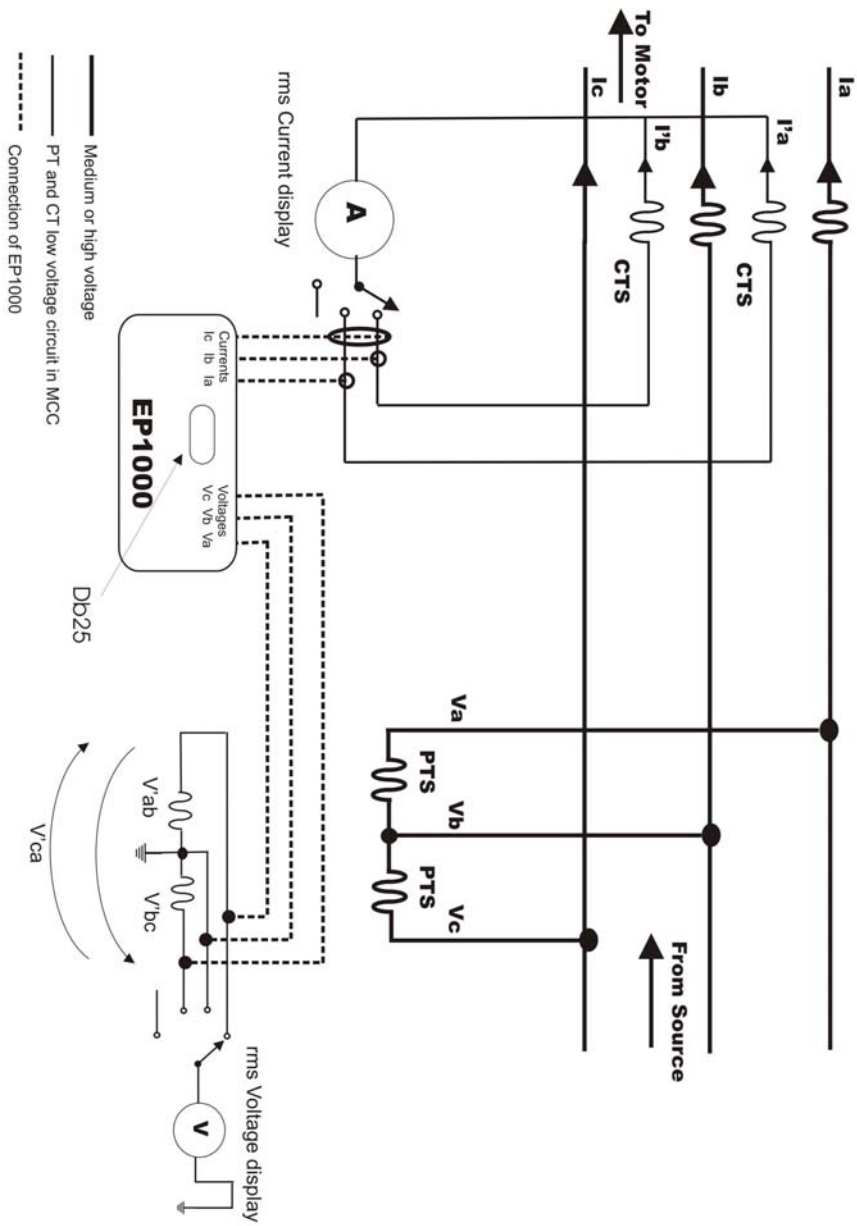



# Appendix E

## References

### List of References:

---

#### Standards:

- [1] NEMA Std. MG 1-2003, Motors and Generators

#### Literature:

- [a] Mohan, Underland, Robbins, *Power Electronics*, Wiley & Sons, 1989, second edition, ISBN 0-471-58408-8.
- [b] El-Hawary, *Electrical Power Systems*, Reston Publishing Company, 1983, ISBN 0-8359-1627-4.
- [c] Gross, *Power System Analysis*, John Wiley & Sons, 1979, ISBN 0-471-01899-6.
- [d] Stevenson, *Elements of Power System Analysis*, 1982, fourth edition, ISBN 0-07-061278-1.
- [e] Fink, Beaty, *Standard Handbook for Electrical Engineers*, McGraw Hill, 2000, fourteenth edition, ISBN 0-07-022005-0.
- [f] Dorf, *The Electrical Engineering Handbook*, CRC Press, 1993, ISBN 0-8493-0185-8.
- [g] Fitzgerald, Kingsley, *Electrical Machinery. The Dynamics and Statics of Electromechanical Energy Conversion*, McGraw-Hill, 1961, New York, Toronto, London, second edition.
- [h] Wiedenbrug, 'Measurement Analysis and Efficiency Estimation of Three Phase Induction Machines Using Instantaneous Electrical Quantities', Dissertation submitted to Oregon State University September 24<sup>th</sup>, 1998.
- [i] Buscarello, 'Practical Solutions to Machinery and Maintenance Vibration Problems', Revised Edition, Update International, Inc., 1997.
- [j] O'Flynn, Moriarty, 'Linear Systems Time Domain and Transform Analysis', Harper & Row, 1987, ISBN 0-06-044925
- [k] Lücke, 'Signalübertragung, Grundlagen der digitalen und analogen Nachrichtenübertragungssysteme', Springer Verlag, third edition, 1988, ISBN 3-540-19435-5.
- [l] Gabel, Roberts, 'Signals and Linear Systems', John Wiley and Sons, second edition, 1980, ISBN 0-471-04958-1
- [m] Karni, Byatt, 'Mathematical Methods in Continuous and Discrete Systems', Holt, Rinehart and Winston, 1982, ISBN 0-03-057038-7

#### Glossary of Terms

**Average Power Factor:** Average of three single phase power factors.

**Clampons:** Split core clamp on CT's.

**Clipons:** Clips for voltage pickup.

**Crest Factor:** Difference between the sine wave peak and the RMS value.

**Current:** The time rate of flow of electric charge, in the direction that a positive moving charge would take and have magnitude equal to the quantity of charge per unit time: measured in amperes.

**Efficiency:** Defined as output power divided by input power.

**Electrical Model:** A group of Electrical thresholds.

**EP:** External Port

**Harmonics:** Periodic motion consisting of one or more vibratory motions that are symmetric about a region of equilibrium, as the motion of a vibrating string of a musical instrument.

**Haystack:** Name of the NEMA guideline to Vibration. Speed versus Frequency in a double logarithmic scale.

**Horsepower:** A foot pound second unit of power, equivalent to 550 foot pounds per second or 745.7 watts.

**Kilowatt:** A unit of power equal to 1000 Watts.

**Load:** What the motor drives.

**MCC:** Motor Control Cabinet

**Motor ID:** Unique name to the motor to be tested.

**NEMA Derating Factor:** Factor between 1 and 0. Displays how much a motor has to be derated, according to NEMA, to accommodate for sub-optimal voltage conditions.

**NEMA Unbalance:** Number commonly defined in percent according to an algorithm specified by NEMA. Displays how much of relative unbalance is part of the voltage condition.

**Newton-Meters:** Metric unit of torque.

**Overcurrent:** Measure of operating current in percent, comparing to the motor's nameplate.

**Phasors:** A vector that represents a sinusoidal varying quantity, as a current or voltage, by means of a line rotating about a point in a plane, the magnitude of the quantity being proportional to the length of the line and the phase of the quantity being equal to the angle between the line and a reference line.

**Pound-Feet:** English system.

**Power Factor:** Relative amount of operating current and voltage used to transmit power. It is defined as the division of real power by the multiplication of current and voltage.

**Service Factor:** Specified on the nameplate, displays the amount with which the rating of the motor may be multiplied for transient operation.

**Test Domains:** The five testing regions within the EXP4000.

**Thresholds:** The point at which a stimulus is of sufficient intensity to produce an affect.

**Torque Ripple:** Measure of time-varying torque divided by steady state, or average torque.

**Total Harmonic Distortion:** Measure of harmonic content to a signal when compared to the amount of fundamental.

**Triggering:** Method with which it is possible to start data acquisition when certain conditions of the signals are met.

**VFD:** Variable Frequency Drive.

**Vibration Model:** Defined as a group of mechanical thresholds.

**Waveform:** Displays the shape of a signal with respect to time.



# Appendix F

## Technical specifications

CD R/W	EXP4000 is shipped with either an internal or external USB interface CD R/W
Computer OS	Microsoft Windows XP Professional or equivalent
Battery	Run time (up to 3+ hours)
Networking	Compliant standards: IEEE 802.11b, IEEE 802.11g
	Data link protocol: Ethernet, Fast Ethernet, Gigabit Ethernet, IEEE 802.11 b, IEEE 8022.11g
Power	Power device – external
	Voltage Requirements: AC (110/230 V (50/60 Hz)
Processor	Data Bus Speed 400 M Hz +
	Processor 1.4 G Hz +
Ram	Installed size – 512 MB/upgradeable to at least 2 GB
Storage	Hard drive – 40 GB+ - 4200 RPM +
Video	Graphics Processor
	Max Resolution (External) 800 x 600 or better
Sensors	Current Transformer, clamp-on, Hall Effect 60/600A DC 10A/100A DC 4000A/7500A DC
	AC Voltage Clips (1,000V)
	Current Transformer clamp-on 150A AC
	Current Transformer clamp-on 10A AC
	Current Transformer clamp-on 1000A AC
	Vibration probe w/magnet- optional
	Grounding Clip
	DC Voltage Clips (500V)
	Current Transformers 3000 A AC
	AC voltage clips
DC voltage clips	Set of 4 color coded
	500 V maximum rated voltage
Vibration sensor (optional)	Sensitivity 100 m (20%)
	Acceleration range 50 g peak
	Amplitude non-linearity 1%
	Frequency response 1.6 Hz to 7 k Hz (10 dB)
	Connector MIL-C-5015
	Splash proof cable Rare earth mounting magnet
Case Environment Dimensions	
	Dust proof, crush resistant 15.11 x 12.40 x 6.94 in.
Power Supply requirements	Input Voltage: 100VAC to 240VAC
	Input Current: 3.0A
	Input Frequency: 50Hz to 60Hz

<b>Current Transformers - AC</b>				
Current Clamp On	10A (AC)	150A (AC)	1000A (AC)	3000A (AC)
Output Signal	10A/1V	150A/1.5V	1000A/2.5V	0.3 mV/A
Measurement Range	0.01A to 10A	.01A to 150A	0.1A to 1000A	5 to 3000A
Insulation	600V RMS	600V RMS	600V RMS	1000 V
Jaw Opening	20mm	20mm	57mm	8 in
Accuracy	0.1 to 0.5A $\leq 2.5\%$ R $\pm 0.1\text{mV}$ 0.5 to 1A: $\leq 2.5\%$ R 1 to 10A: $\leq 1\%$ R	0.1 to 1A: $2.0\%R \pm 0.2\text{mV}$ 10 to 80A: $1\%R \pm 0.2\text{mV}$ 80 to 150A: $1.5\%R \pm 0.2\text{mV}$	0.1 to 10A: $\leq 3\%$ $\pm 0.1\text{A}$ of R 10A: $\leq 3\%$ of R 50A: $\leq 1.5\%$ of R 200A: $\leq 0.75\%$ of R 1000A: $< 0.5\%$ of R	1% of Reading
Weight	3 * 180g	3 * 180g	3 x 550g	
Dimensions	139 x 51 x 30mm ea	139 x 51 x 30mm ea.	111 x 216 x 45 mm ea.	
<b>Current Transformers - DC</b>				
	10A/100ADC	60A/600ADC	4000A/7500ADC	
Output	10A: 100mV/A 100A: 10mV/A	60: 10mV/A 600A: 1mV/A	4000A/2 V 7500A/1.5 V	
Measurement range	100mA to 100 A	0.2A to 600A	40A – 7500A	
Overload	Red LED indicates overload	2000 ADC cont. up to 1 kHz		
Working Voltage	600 Vrms	600 Vrms	600 V	
Accuracy	50mA to 10A: 3% of reading $\pm 50\text{mA}$ 500mA to 40A: $\pm 4\%$ of reading $\pm 50\text{mA}$ 40A to 100A: $\pm 15\%$ max @ 100A	<b>60A:</b> 0.5 to 40A: 1.5% of reading $\pm 0.5\text{A}$ 40 to 60A: 1.5% of reading <b>600A:</b> 0.5 to 100A: 1.5% of Reading $\pm 1\text{A}$ 100 to 400A: 2% of Reading 400 to 600A: 2.5% of Reading	<b>1.5%</b>	
Weight	11.6 oz	15 oz	4.25 lbs	
Dimensions	231 x 36 x 67 mm	224 x 97 x 44 mm	13.23 x 5.4 x 2.0 in.	
<b>Connectors</b>				
Function	Number	Type		
AC/DC Voltage Port	1	Cannon Jack		
AC/DC Current Port	1	Cannon Jack		
Outlet	1	Standard 110-230V		
EP/Vib Port	1	Cannon Jack		

---

**A**

**Acquire EP** · 37, 41  
Assign Elec. Test Model · 42

---

**C**

**Channel** · 44  
Connecting · 111  
**Continuous** · 46  
**Create Elec. Test Model** · 42  
**Create Motor** · 37  
**Current Clamp On** · 150  
Current Unbalances · 17, 24

---

**D**

Database · 29, 35, 36  
Database Management · 29  
databases · 29  
Demodulated Spectrum · 53  
derating factor · 31

---

**E**

Edit Elec. Test Model · 43  
Efficiency test · 22  
Electrical · 129, 146  
**Energy Assessment** · 127  
Environmental · 15

---

**F**

File Menu · 35  
**Freeze** · 44

---

**H**

**H position** · 44  
Harmonic Distortion · 17, 18, 127, 147  
Harmonics · 17, 20, 25, 127, 146

---

**L**

**Load** · 44, 127, 146  
**Loop Acquisition** · 46

---

**M**

**MCC** · 14, 113, 114, 123, 146  
Menus · 35  
**Motor Performance** · 127

---

**N**

NEMA · 31, 146

---

**O**

Operating Condition · 17, 21, 129  
Options · 48  
overcurrent test · 23  
Override Speed · 49

---

**P**

Panels · 31  
Payback Period · 17, 23, 129  
Phase current · 43  
Phase to ground · 43  
Phase to phase · 43  
**Power** · 17, 19, 30, 36, 59, 65, 70, 127, 132, 145, 146  
**Power Condition** · 127  
Power Quality · 17  
**Print Currents** · 45  
**Print Graph** · 44  
**Print Panel** · 44  
**Print Summary** · 35, 36, 128  
**Print Voltages** · 45

---

**R**

**Recall/Delete** · 35  
**Report and Exit** · 35  
rotor bar test · 25

---

**S**

**Save** · 44  
**Scope** · 43, 44  
**Sec/Div** · 44  
Sensors · 113  
Serial · 37, 41  
Shipment · 16  
Spectrum Domain · 24, 53

---

**T**

Test Notes · 48  
**Test Results** · 35  
**Timed** · 46  
Tools Menu items · 43  
Torque Domain · 53, 54  
Torque Ripple · 53, 54, 55, 147  
Total Distortion · 17, 18, 127  
**Trigger** · 45

---

**U**

**Units/Div** · 44  
User Level · 48

---

**V**

**V position** · 44  
V/I Spectrum · 25  
VFD Details · 59, 61, 127  
Vibration · 43, 71, 129, 146, 147, 149  
Vibration probe · 149  
Voltage Clips · 149  
voltage unbalance test · 30, 31

---

**W**

Waveforms · 17, 26, 30, 60